

SERVICE MANUAL

FE-1 CHASSIS

<i>MODEL</i>	<i>COMMANDER</i>	<i>DEST</i>	<i>CHASSIS NO.</i>	<i>MODEL</i>	<i>COMMANDER</i>	<i>DEST</i>	<i>CHASSIS NO.</i>
KV-21C5B	RM-883	French	SCC-Q02H-A	KV-21X5A	RM-883	Italian	SCC-Q06K-A
KV-21C5D	RM-883	AEP	SCC-Q04K-A	KV-21X5B	RM-883	French	SCC-Q02J-A
KV-21C5E	RM-883	Spanish	SCC-Q05K-A	KV-21X5D	RM-883	AEP	SCC-Q04L-A
KV-21C5K	RM-883	OIRT	SCC-Q03S-A	KV-21X5E	RM-883	Spanish	SCC-Q05L-A
KV-21C5R	RM-883	OIRT	SCC-Q03R-A	KV-21X5K	RM-883	OIRT	SCC-Q03U-A
				KV-21X5L	RM-883	Irish	SCC-Q07D-A
				KV-21X5R	RM-883	OIRT	SCC-Q03T-A
				KV-21X5U	RM-883	UK	SCC-Q01F-A



TRINITRON® COLOR TV
SONY®





ITEM MODEL	Television System	Stereo System	Channel Coverage	Color System
Italian	B/G/H	GERMAN Stereo	ITALIA VHF : A-H2 (C) UHF : 21-69 PAL B/G/H VHF : E2-E12 UHF : E21-E69 CABLE TV (1) : S1-S41 CABLE TV (2) : S01-S05, M1-M10, U1-U10	PAL, SECAM NTSC4.43, NTSC3.58 (VIDEO IN)
French	B/G/H, D/K, L, I	GERMAN/NICAM Stereo	L VHF : F02-F10 UHF : F21-F60 CABLE : B-Q B/G/H VHF : E2-E12 UHF : E21-E69 CABLE TV (1) : S1-S41 CABLE TV (2) : S01-S05, M1-M10, U1-U10 ITALIA VHF : A-H2 (C) UHF : 21-69 I UHF : B21-B69	PAL, SECAM NTSC4.43, NTSC3.58 (VIDEO IN)
AEP	B/G/H	GERMAN Stereo	PAL B/G/H VHF : E2-E12 UHF : E21-E69 CABLE TV (1) : S1-S41 CABLE TV (2) : S01-S05, M1-M10, U1-U10 ITALIA VHF : A-H2 (C) UHF : 21-69 D/K VHF : R01-R12 UHF : R21-R69	PAL, SECAM NTSC4.43, NTSC3.58 (VIDEO IN)
Spanish	B/G/H, D/K	GERMAN/NICAM Stereo	PAL B/G VHF : E2-E12 UHF : E21-E69 CABLE TV (1) : S1-S41 CABLE TV (2) : S01-S05, M1-M10, U1-U10 ITALIA VHF : A-H2 (C) UHF : 21-69	PAL, SECAM NTSC4.43, NTSC3.58 (VIDEO IN)
OIRT	B/G/H, D/K	KV-21C5K/21X5K GERMAN/NICAM Stereo KV-21C5R/21X5R GERMAN Stereo	B/G/H VHF : E2-E12 UHF : E21-E69 CABLE TV (1) : S1-S41 D/K VHF : R01-R12 UHF : R21-R69	PAL, SECAM NTSC4.43, NTSC3.58 (VIDEO IN)
Irish	I	NICAM Stereo	VHF : A-C, D-J VHF : 21-69 CABLE CHANNELS S1-S20 HYPERBAND S21-S41	PAL NTSC4.43, NTSC3.58 (VIDEO IN)
UK	I	NICAM Stereo	UHF : B21-B69	PAL NTSC4.43, NTSC3.58 (VIDEO IN)

MODEL	21X5A	21C5B 21X5B	21C5D 21X5D	21C5E 21X5E	21C5K 21X5K	21X5L	21C5R 21X5R	21X5U
Power Consumption	72W	72W	72W	72W	72W	72W	72W	105W

[PICTURE TUBE]

Super Trinitron
Approx. 55cm (21 inches)
(Approx. 51cm picture measured
diagonally)
110 degree deflection



[FRONT]

-  Video input - phono jack
-  Audio inputs - phono jacks
-  Headphone jacks : stereo minijack

Input/Output Terminals

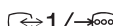
[REAR]

-  21-pin Euro connector (CENELEC standard).
 - Inputs for Audio and Video signals.
 - Inputs for RGB.
 - Outputs of TV Video and Audio signals.

-  21-pin Euro connector.
 - inputs for Audio and Video signals.
 - inputs for S Video.
 - outputs for Audio and Video signals (selectable).
-  Phono Jack
 - Outputs for Audio Signals

- Sound output 2 x 14W (Music Power)
- Power requirements 220 - 240V
- Dimensions Approx 620x457x467mm (KV-21C5)
Approx 527x449x466mm (KV-21X5)
- Weight Approx 22kg (KV-21C5)
Approx 23kg (KV-21X5)
- Supplied accessories RM-883 Remote Commander (1)
IEC designated R6 battery (2)
- Other features NICAM*, FASTEXT, TOPTXT
*(KV-21C5B/21C5E/21C5K/
KV-21X5B/21X5E/21X5K/
KV-21X5L/21X5U only)

[RM-883]

Remote control system Infrared control
 Power requirements 1.5V dc
 2 batteries IEC designation
 R6 (size AA)
 Dimensions Approx 65x225x21mm (w/h/d)
 Weight Approx 157g (Not including battery)

Design and specifications are subject to change without notice.

Model Name Item	KV-21X5A	KV-21C5B KV-21X5B	KV-21C5D KV-21X5D	KV-21C5E KV-21X5E	KV-21C5K KV-21X5K	KV-21C5R KV-21X5R	KV-21X5L KV-21X5U
	Pal Comb	OFF	OFF	OFF	OFF	OFF	OFF
PIP	OFF	OFF	OFF	OFF	OFF	OFF	OFF
RGB Priority	OFF	ON	ON	ON	OFF	OFF	OFF
Woofers Box	OFF	OFF	OFF	OFF	OFF	OFF	OFF
Scart 1	ON	ON	ON	ON	ON	ON	ON
Scart 2	ON	ON	ON	ON	ON	ON	ON
Front in (3)	ON	ON	ON	ON	ON	ON	ON
Scart 4	OFF	OFF	OFF	OFF	OFF	OFF	OFF
Projector	OFF	OFF	OFF	OFF	OFF	OFF	OFF
AKB in 16:9 mode	ON	ON	ON	ON	ON	ON	ON
Norm B/G	ON	ON	ON	ON	ON	ON	OFF
Norm I	OFF	ON	OFF	OFF	OFF	OFF	ON
Norm D/K	OFF	ON	OFF	ON	ON	ON	OFF
Norm AUS	OFF	OFF	OFF	OFF	OFF	OFF	OFF
Norm L	OFF	ON	OFF	OFF	OFF	OFF	OFF
Norm SAT	OFF	OFF	OFF	OFF	OFF	OFF	OFF
Norm M	OFF	OFF	OFF	OFF	OFF	OFF	OFF
Teletext	ON	ON	ON	ON	ON	ON	ON
Nicam Stereo	OFF	ON	OFF	ON	ON	OFF	ON
Language Preset	Italian	French	German	Spanish	OIRT	OIRT	English

WARNING (KV-21X5L/KV-21X5U only)

The flexible mains lead is supplied connected to a **B.S. 1363** fused plug having a fuse of **5 AMP** capacity. Should the fuse need to be replaced, use a **5 AMP FUSE** approved by **ASTA** to **BS 1362**, ie one that carries the  mark.

IF THE PLUG SUPPLIED WITH THIS APPLIANCE IS NOT SUITABLE FOR THE OUTLET SOCKETS IN YOUR HOME, IT SHOULD BE CUT OFF AND AN APPROPRIATE PLUG FITTED. THE PLUG SEVERED FROM THE MAINS LEAD MUST BE DESTROYED AS A PLUG WITH BARED WIRES IS DANGEROUS IF ENGAGED IN A LIVE OUTLET SOCKET.

When an alternative type of plug is used it should be fitted with a **5 AMP FUSE**, otherwise the circuit should be protected by a **5 AMP FUSE** at the distribution board.

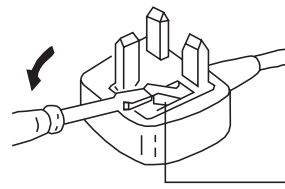

How to replace the fuse.
 Open the fuse compartment with a screwdriver blade and replace the fuse.

21 pin connector (↔ 1/ →⊙⊙⊙ , ↔ 2/ →S)

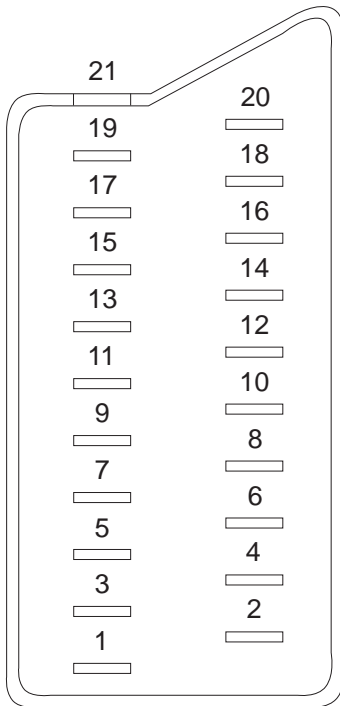
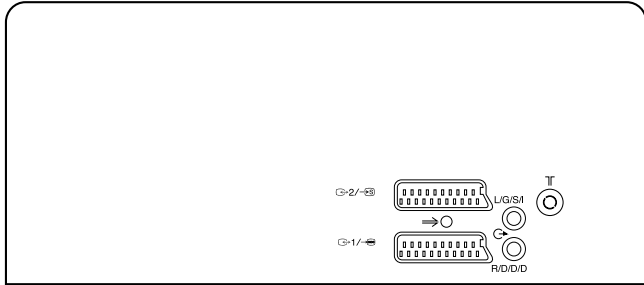

Pin No	1	2	4	Signal	Signal level
1	○	○	○	Audio output B (right)	Standard level : 0.5V rms Output impedance : Less than 1kohm*
2	○	○	○	Audio output B (right)	Standard level : 0.5V rms Output impedance : More than 10kohm*
3	○	○	○	Audio output A (left)	Standard level : 0.5V rms Output impedance : Less than 1kohm*
4	○	○	○	Ground (audio)	
5	○	○	○	Ground (blue)	
6	○	○	○	Audio input A (left)	Standard level : 0.5V rms Output impedance : More than 10kohm*
7	○	●	●	Blue input	0.7 +/- 3dB, 75 ohms positive
8	○	○	○	Function select (AV control)	High state (9.5-12V) : Part mode Low state (0-2V) : TV mode Input impedance : More than 10K ohms Input capacitance : Less than 2nF
9	○	○	○	Ground (green)	
10	○	○	○	Open	
11	○	●	●	Green	Green signal : 0.7 +/- 3dB, 75 ohms, positive
12	○	○	○	Open	
13	○	○	○	Ground (red)	
14	○	○	○	Ground (blanking)	
15	○	-	-	Red input	0.7 +/- 3dB, 75 ohms, positive
	-	○	○	(S signal Chroma input)	0.3 +/- 3dB, 75 ohms, positive
16	○	●	●	Blanking input (Ys signal)	High state (1-3V) Low state (0-0.4V) Input impedance : 75 ohms
17	○	○	○	Ground (video output)	
18	○	○	○	Ground (video input)	
19	○	○	○	Video output	1V +/- 3dB, 75ohms, positive sync 0.3V (-3+10dB)
20	○	-	-	Video input	1V +/- 3dB, 75ohms, positive sync 0.3V (-3+10dB)
	-	○	○	Video input Y (S signal)	1V +/- 3dB, 75ohms, positive sync 0.3V (-3+10dB)
21	○	○	○	Common ground (plug, shield)	

○ Connected ● Not Connected (open) * at 20Hz - 20kHz

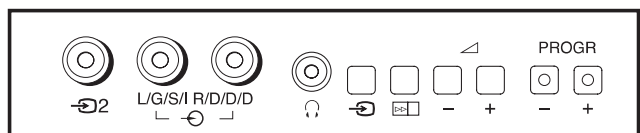

TABLE OF CONTENTS

<i>Section</i>	<i>Title</i>	<i>Page</i>	<i>Section</i>	<i>Title</i>	<i>Page</i>
1. GENERAL			4. CIRCUIT ADJUSTMENTS		
	Overview of TV buttons	6	4-1.	Electrical Adjustments	20
	Using Select Mode	6	4-2.	Test Mode 2	23
	Adjusting the Picture	7	4-3.	FE-1 Self Diagnostic Software	24
	Adjusting the Sound	7			
	Using the Sleep Timer	8	5. DIAGRAMS		
	Using the Wake Up Timer	8	5-1.	Block Diagram	25
	Viewing Teletext	9	5-2.	Circuit Board Location	30
	Exchanging Programme Pos	9	5-3.	Schematic Diagrams and Printed Wiring Boards	30
	Manually Tuning the TV	10		* A Board	35
	Fine-Tuning Channels	10		* S1 Board	40
	Using Optional Equipment	11		* C Board	43
	Troubleshooting	11	5-4.	Semiconductors	45
			5-5.	IC Blocks	47
2. DISASSEMBLY			6. EXPLODED VIEWS		
2-1.	Rear Cover Removal	12	6-1.	KV-21C5 Chassis	48
2-2.	Chassis Assy Removal	12	6-2.	KV-21C5 Picture Tube	49
2-3.	Service Position	13	6-3.	KV-21X5 Chassis	50
2-4.	S1 Board Removal	13	6-4.	KV-21X5 Picture Tube	51
2-5.	Picture Tube Removal	14			
2-6.	Removal and Replacement of the Main-Bracket bottom plates	15	7. ELECTRICAL PARTS LIST		52
3. SET-UP ADJUSTMENTS					
3-1.	Beam Landing	16			
3-2.	Convergence	17			
3-3.	Screen [G2] White Balance	19			
3-4.	Focus	19			

CAUTION

SHORT CIRCUIT THE ANODE OF THE PICTURE TUBE AND THE ANODE CAP TO THE METAL CHASSIS, CRT SHIELD, OR THE CARBON PAINTED ON THE CRT, AFTER REMOVAL OF THE ANODE CAP

WARNING !!

AN ISOLATING TRANSFORMER SHOULD BE USED DURING ANY SERVICE WORK TO AVOID POSSIBLE SHOCK HAZARD DUE TO LIVE CHASSIS. THE CHASSIS OF THIS RECEIVER IS DIRECTLY CONNECTED TO THE POWER LINE.

SAFETY-RELATED COMPONENT WARNING !!

COMPONENTS IDENTIFIED BY SHADING AND MARKED  ON THE SCHEMATIC DIAGRAMS, EXPLODED VIEWS AND IN THE PARTS LIST ARE CRITICAL FOR SAFE OPERATION. REPLACE THESE COMPONENTS WITH SONY PARTS WHOSE PART NUMBERS APPEAR AS SHOWN IN THIS MANUAL OR IN SUPPLEMENTS PUBLISHED BY SONY.

ATTENTION

APRES AVOIR DECONNECTE LE CAP DE L'ANODE, COURT-CIRCUITER L'ANODE DU TUBE CATHODIQUE ET CELUI DE L'ANODE DU CAP AU CHASSIS METALLIQUE DE L'APPAREIL, OU AU COUCHE DE CARBONE PEINTE SUR LE TUBE CATHODIQUE OU AU BLINDAGE DU TUBE CATHODIQUE.

ATTENTION !!

AFIN D'EVITER TOUT RISQUE D'ELECTROCUTION PROVENANT D'UN CHÂSSIS SOUS TENTION, UN TRANSFORMATEUR D'ISOLEMENT DOIT ETRE UTILISÉ LORS DE TOUT DÉPANNAGE. LE CHÂSSIS DE CE RÉCEPTEUR EST DIRECTMENT RACCORDÉ À L'ALIMENTATION SECTEUR.

ATTENTION AUX COMPOSANTS RELATIFS À LA SÉCURITÉ !!

LES COMPOSANTS IDENTIFIÉS PAR UNE TRAME ET PAR UNE MARQUE  SUR LES SCHÉMAS DE PRINCIPE, LES VUES EXPLOSÉES ET LES LISTES DE PIÈCES SONT D'UNE IMPORTANCE CRITIQUE POUR LA SÉCURITÉ DU FONCTIONNEMENT, NE LES REMPLACER QUE PAR DES COMPOSANTS SONY DONT LE NUMÉRO DE PIÈCE EST INDIQUÉ DANS LE PRÉSENT MANUEL OU DANS DES SUPPLÈMENTS PUBLIÉS PAR SONY.

SECTION 1 GENERAL

The operating instructions mentioned here are partial abstracts from the Operating Manual. The page numbers of the Operating Instruction Manual remain as in the manual.

Basic TV Features

Overview of TV Buttons

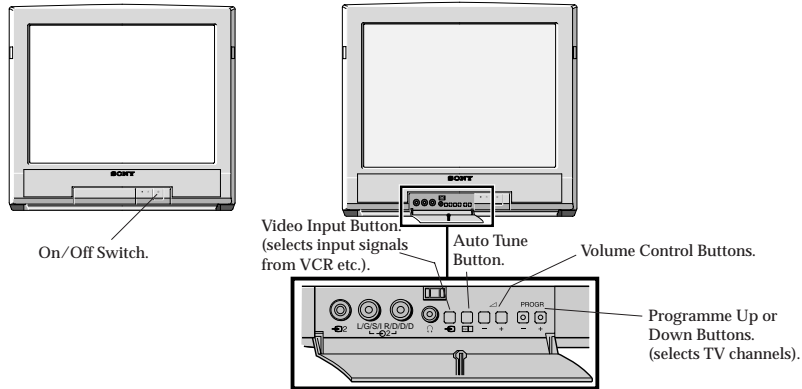

Overview of Remote Control Buttons

To Mute Sound

Press to mute TV sound. Press again to restore the sound.

To Select Channels

Press to select channels.

For double-digit programme numbers, e.g. 23, press **-/** first, then the buttons 2 and 3. If you enter an incorrect first digit, this should be corrected by entering another digit (0 - 9) and then selecting **-/** button again to enter the programme number of your choice

To Change Screen Format

Press to view programmes in 16:9 mode. Press again to return to 4:3 mode.

To Adjust TV Volume

Press to adjust the volume of the TV.

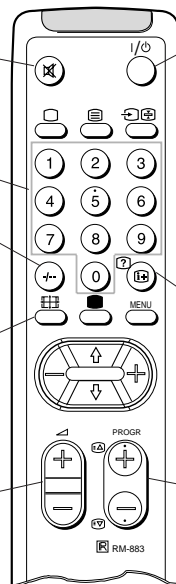

To Temporarily Switch Off TV

Press to temporarily switch off TV. Press again to switch on TV from standby mode.

To save energy we recommend switching off completely when TV is not in use.
NOTE: After 15 - 30 minutes without a TV signal and without any button being pressed, the TV switches automatically into standby mode.

To Reveal On Screen Information

Press to reveal all on-screen indications. Press again to cancel.

To Select Channels

Press to select channels.

Additional TV Features

Using Select Mode

You can select different preset picture and sound modes.

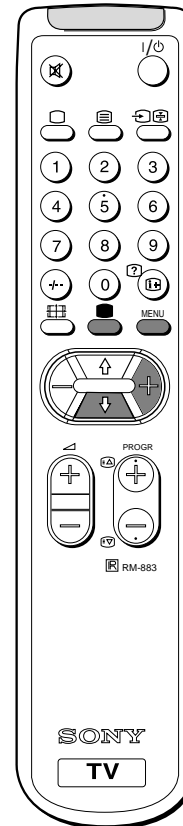

1 Press the MENU button on the remote control to display the menu on the TV screen.

2 With the cursor pointing at the symbol on the TV screen as shown, press the yellow button.

3 Press the blue button to select the desired mode:

- Personal Mode - reverts to settings made in "Adjusting the Picture and Sound" sections of the manual
- Movie Mode - for films
- Live Mode - for live broadcast programmes

4 Press the MENU button to remove the menu display from the TV screen.

Note: The mode selected in step 3 is now stored.

Changing Modes Quickly

1 Press the button on the remote control to display the three different modes.



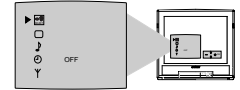

2 Press the button again to select your desired mode.



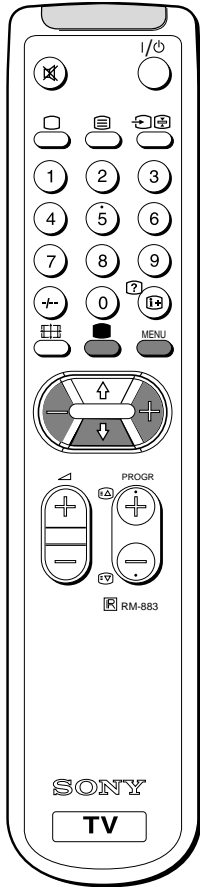





Adjusting the Picture

Although the picture is adjusted at the factory, you can modify it to suit your own requirement.



- 1 Press the  button on the remote control to display the three different modes on the TV screen.
- 2 Press the  button to highlight the personal mode symbol  as shown.
- 3 Press the MENU button to display the menu on the TV screen.
- 4 Press the blue button on the control to select the  symbol on the TV screen then press the yellow button.
- 5 Press the blue button to select the item you wish to change (see below).
- 6 Press the red or yellow button to alter the selected item.
- 7 Press the MENU button to remove the menu display from the TV screen.



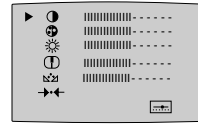
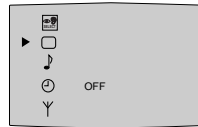
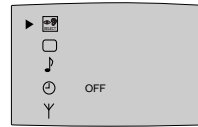
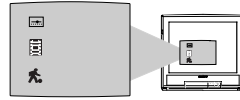

Symbol	Item
	• Contrast
	• Colour
	• Brightness
	• Sharpness
	• Hue control (only for NTSC video signals)
	• Reset - resets to factory preset picture level
	• Represents the mode selected in the "Using Select Mode" section.



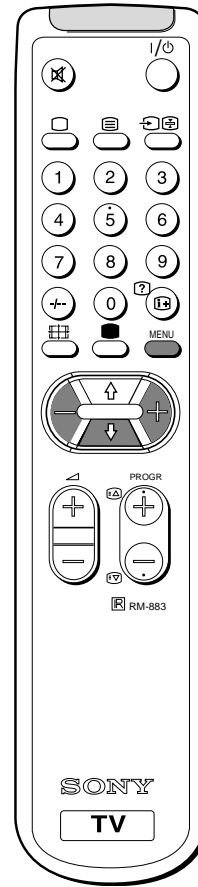



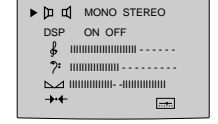
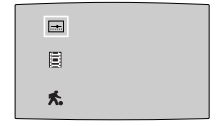
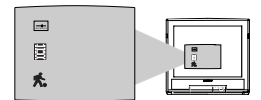

Adjusting the Sound

Although the sound is adjusted at the factory, you can modify it to suit your own requirement.



- 1 Press the  button on the remote control to display the three different modes on the TV screen.
- 2 Press the  button to highlight the personal mode symbol  as shown.
- 3 Press the MENU button to display the menu on the TV screen.
- 4 Press the blue button to select the  symbol on the TV screen then press the yellow button.
- 5 Press the blue button to select the item you wish to change (see below).
- 6 Press the red or yellow button to alter the selected item.
- 7 Press the MENU button to remove the menu display from the TV screen.



Symbol	Item
	• Mono/Stereo A:Channel 1 sound or Mono sound/ B:Channel 2 sound (to select your desired language from a dual sound broadcast)
DSP	• On/Off (digital sound processor)
	• Treble
	• Bass
	• Balance
	• Reset (resets to factory preset sound level)
	• Represents the mode selected in the "Using Select Mode" section of the manual.

Using the Sleep Timer

The TV may be set to switch automatically to the standby mode after a length of time chosen by you. You may set the time in 15 minute steps up to 4 hours.

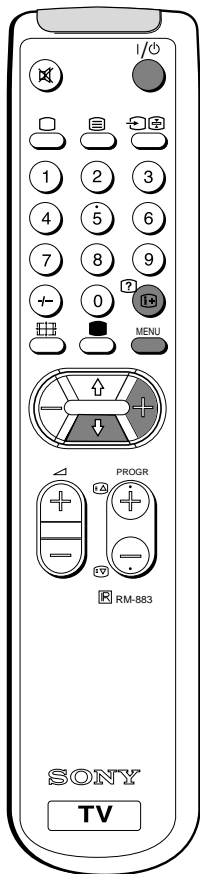

1 Press the MENU button on the remote control to display the menu on the TV screen.

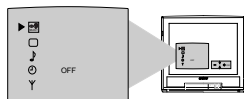

2 Press the blue button on the control to select the  symbol on the TV screen, then press the yellow button.

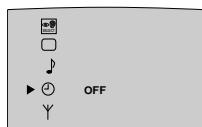

3 Press the yellow button repeatedly until the required amount of time delay appears on the screen.

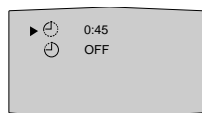

4 Once the time delay has been selected, press the MENU button to remove the on-screen display.

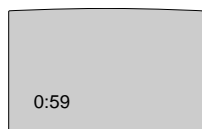

One minute before standby, the display shown appears on the screen.

Notes:

- When watching TV, press the  button to display time remaining.
- To return to normal operation from standby mode, press the I/O button.

Using the Wake Up Timer

The TV may be set to switch on automatically after a length of time chosen by you. You may set the time in 15 minute steps up to 12 hours.

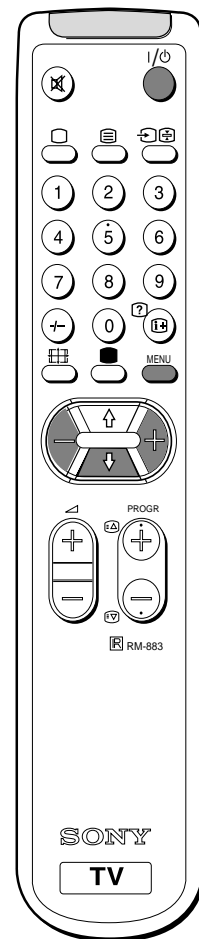

1 Press the MENU button on the remote control to display the menu on the TV screen.

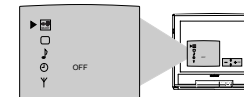

2 Press the blue button on the control to select the  symbol on the TV screen, then press the yellow button.

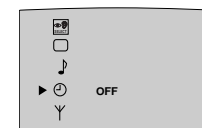

3 Press the blue button on the control to select the  symbol on the TV screen, then press the yellow button.



4 Press the red or yellow button to set the time.

0:00 (OFF) 0:15 0:30 0:45 -----12:00

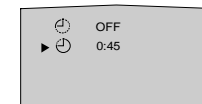

5 Press the standby button I/O. The standby indicator on the TV flashes regularly to indicate that the Wake Up Timer is active. After the selected length of time, the TV switches on automatically.

Notes:

- If you use the "Wake Up Timer" to switch the TV on and for one hour after switching on, no TV or Remote Control button is pressed, the TV switches itself back into Standby mode and the indicator  on the TV lights.
- Any temporary power failure will cause a malfunction in the "Wake Up Timer" and you will have to reset the "Wake Up Timer".

Viewing Teletext

Teletext is an information service transmitted by most TV stations.

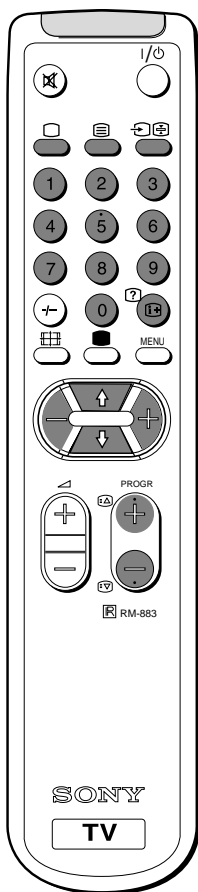

Selecting Teletext

- 1 Press a number button on the remote control to select the channel which carries the teletext service you wish to receive.
- 2 Press the button on the remote control to switch on teletext.
- 3 Input three digits for the page number using the numbered buttons on the control.
- 4 Press the button to switch off teletext.

Note: Teletext errors may occur if the broadcasting signals are weak.

Using Other Teletext Functions

To Superimpose Teletext on to the TV

Press once in teletext mode or twice in TV mode to superimpose teletext on to the TV screen. Press again to cancel teletext mode.

To Move to Next or Preceding Page

Press PROG +/- on the remote control to select the previous or next page.

To Freeze a Teletext Page

Press on the control to freeze the page. Press again to cancel the freeze.

Revealing concealed information (eg: answers to a quiz).

Press to reveal information. Press again to conceal the information.

Using colour buttons to access pages (Fastext/TOptext)

When the colour coded menu appears at the bottom of a page, press the colour button (green, red, yellow or blue) to access the corresponding page.

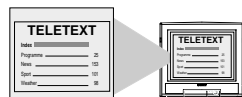

Exchanging Programme Positions

After tuning you may wish to change the order in which the channels appear on the TV. You may wish for example to exchange the channel on programme number 8 with the channel on programme number 4.

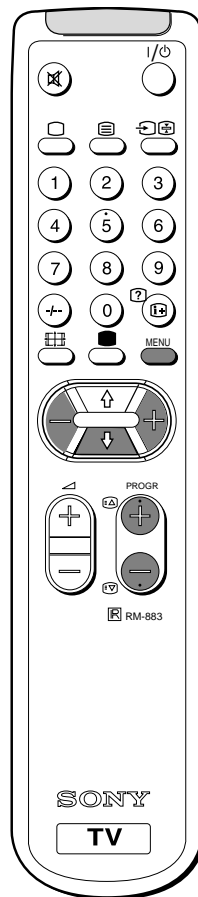

- 1 Press the MENU button on the remote control.
- 2 Press the blue button on the control to select on the TV screen, then press the yellow button.
- 3 Press the blue button to select then press the yellow button.
- 4 With the cursor pointing at PROGR on the TV screen as shown, press PROG + or - button until the channel you wish to rearrange appears on screen, then press the blue button once.
- 5 Press the red or yellow button to select the new programme number (e.g. PROGR 04) for your selected channel.
- 6 Press the blue button to select then press the yellow button to exchange the channels.
- 7 Repeat steps 4 to 6 if you wish to change the order of the other channels on your TV, then press MENU to return to normal TV screen.
- 8 Press the PROG +/- button to view your selected channels on their new programme numbers.

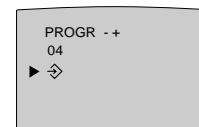
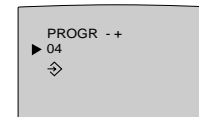
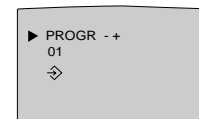
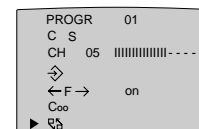
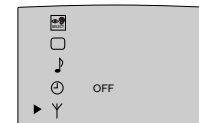
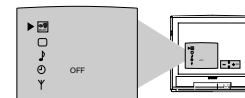

Manually Tuning the TV

You have already tuned the TV to receive all available channels using the 'Automatically Tuning the TV' procedure at the start of this manual. You can however carry out this operation manually using the following instructions.

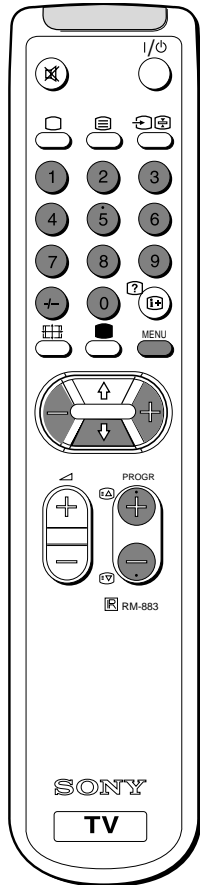

- 1 Press the MENU button on the remote control to display the menu on the TV screen.
- 2 Press the blue button to select the Ψ symbol on the TV screen then press the yellow button.
- 3 With the cursor pointing at **PROGR** on the TV screen as shown, press **PROGR + or -** button on the remote control to allocate a programme number to the channel (eg **PROGR 01**). For double digit numbers e.g. 55, press the **-/--** button on the remote control then the corresponding numbered buttons.
- 4 Press the blue button to select the channel type (**C** to preset a regular channel or **S** to preset a cable channel) then press the yellow button to highlight the desired channel type.
- 5 Press the blue button to select the tuning bar scale then press the yellow or red button once to start the channel search. (Yellow to search up the scale or red to search down). When a channel is found it appears on the TV screen.
- 6 If you do not wish to store this channel on the programme number you selected, press the yellow or red button to continue searching for the desired channel.
- 7 If this is the channel you wish to store, press the blue button to select the $\Leftarrow F \Rightarrow$ symbol on the screen then press the yellow button to store.
- 8 Repeat steps 3 to 7 if you wish to store more channels then press the **MENU** button to remove the menu from the TV screen.

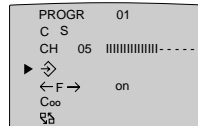
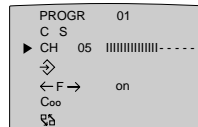
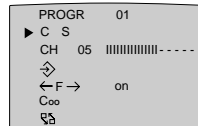
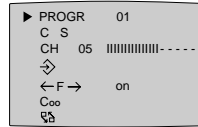
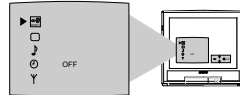

Fine-Tuning Channels

If a channel is slightly off tune, you can use this fine tune procedure to obtain a better picture reception.

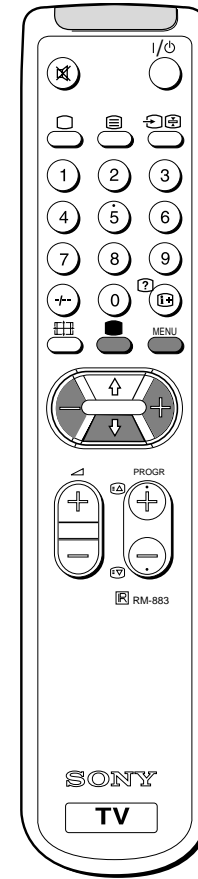

- 1 With the channel you wish to fine-tune on the screen, press the **MENU** button on the remote control. The menu display appears on the TV screen.
- 2 Press the blue button on the remote control to select the Ψ symbol on the TV screen then press the yellow button.
- 3 Press the blue button to select the $\Leftarrow F \Rightarrow$ symbol on the TV screen then press the red or yellow button to adjust the tuning.
- 4 Press the blue button to select the $\Leftarrow F \Rightarrow$ symbol on the TV screen then press the yellow button to store.
- 5 Press the **MENU** button to remove the menu from the TV screen.

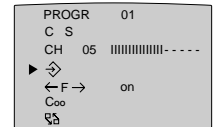
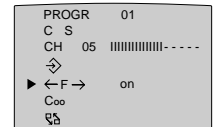
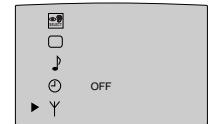
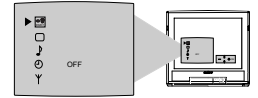

Optional Connections



Using Optional Equipment

You can connect optional audio or video equipment to your TV, such as a VCR, a camcorder or video games as shown.

Select and View the Input Signal

- 1 Connect your equipment to the designated TV socket.
- 2 Press the  button repeatedly on your remote control until the correct input symbol appears on the TV screen.

Symbol Input signals

- | | |
|---|--|
|  | • Audio/video input signal through the Euro AV connector D |
|  | • RGB input signal through the Euro AV connector D |
|  | • Audio/video input signal through the phono sockets A and B |

- 3 Switch on the connected equipment.
- 4 To return to normal TV picture, press the  button on the remote control.

Note: To avoid picture distortion, do not connect equipment to the **A** and **D** connectors at the same time.

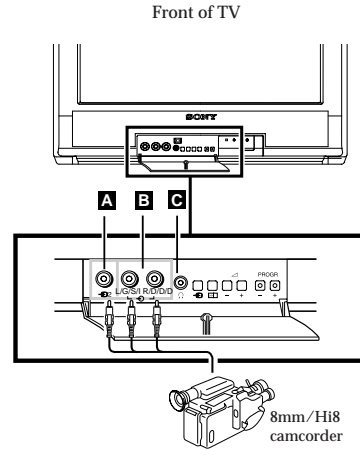

Additional Information

Connecting a VCR

We recommend you tune in the VCR signal to TV programme number '0' using the 'Manually Tuning in the TV' section of this instruction manual.

Connecting Headphones

Plug in your headphones to the socket **C** on the front of the TV set.

For Mono Equipment



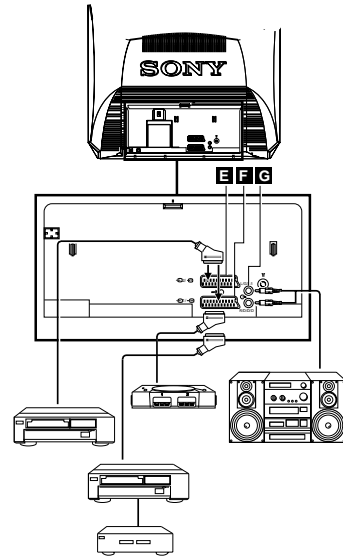









Connect the phono plug to the L/G/S/I socket on the front of the TV and select  input signal using the instructions above. Finally, refer to the 'Adjusting the Sound' section of this manual and select 'A' on the sound menu screen.



Additional Information

Troubleshooting

Here are some simple solutions to problems which may affect the picture and sound.

Problem	Solution
No picture (screen is dark), no sound	<ul style="list-style-type: none"> • Plug the TV in. • Press the  button on the front of TV. • If the  indicator is on press  button or a programme number button on the remote control. • Check the aerial connection. • Check that the selected video source is on. • Turn the TV off for 3 or 4 seconds and then turn it on again using the  button on the front of the TV.
Poor or no picture (screen is dark), but good sound	<ul style="list-style-type: none"> • Using the MENU system, select the Picture Adjustment display. Adjust the brightness, picture and colour balance levels. • From the Picture Adjustment display select  to return to the factory settings.
Poor picture quality when watching a RGB video source.	<ul style="list-style-type: none"> • Press the  button repeatedly on the remote control until the RGB symbol  is displayed on the screen.
Good picture, no sound	<ul style="list-style-type: none"> • Press the  button on the remote control. • If  is displayed on the screen, press the  button on the remote control.
No colour on colour programmes	<ul style="list-style-type: none"> • Using the MENU system, select the Picture Adjustment display. Adjust the colour balance. • From the Picture Adjustment display select  to return to the factory settings.
Distorted picture when changing programmes or selecting teletext	<ul style="list-style-type: none"> • Turn off any equipment connected to the 21 pin Euro connector on the rear of the TV.
Remote control does not function	<ul style="list-style-type: none"> • Replace the batteries.
Noisy picture when viewing TV channel	<ul style="list-style-type: none"> • Adjust fine tuning to obtain better picture reception.
The standby indicator  on the TV flashes even though the "Wake Up Timer" is not in use.	<ul style="list-style-type: none"> • Contact your nearest Sony service centre.

- If you continue to have these problems, have your TV serviced by qualified personnel.
- NEVER open the casing yourself.

SECTION 2 DISASSEMBLY

2-1. REAR COVER REMOVAL

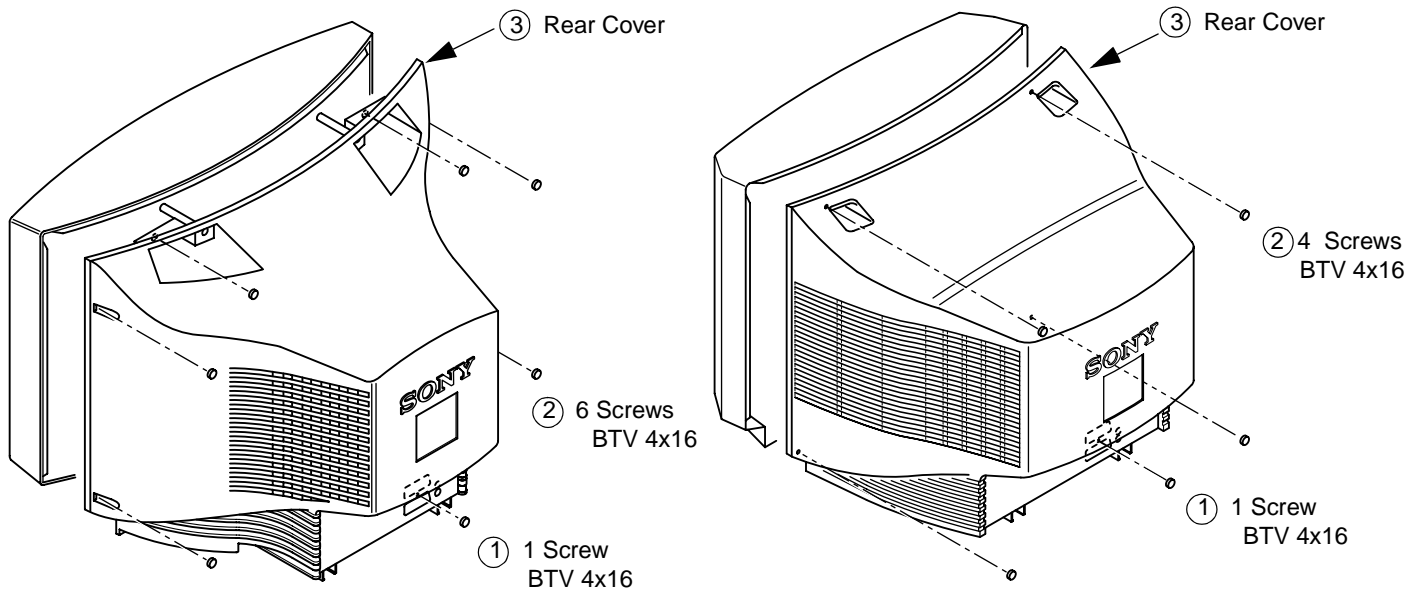

2-2. CHASSIS ASSY REMOVAL

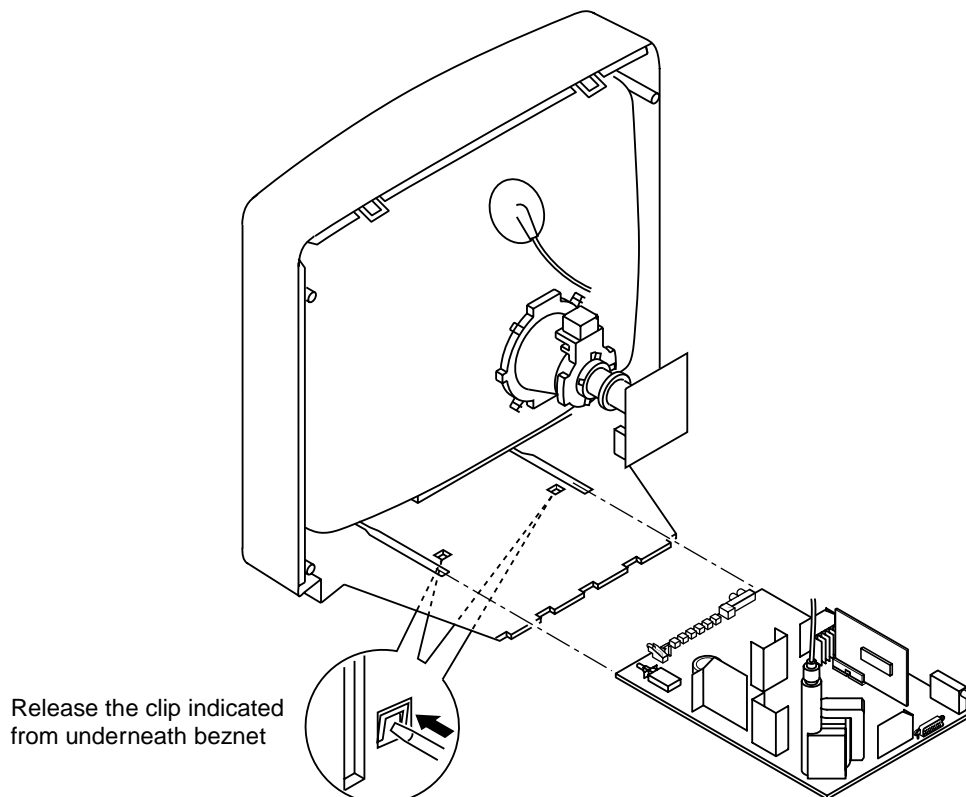

2-3. SERVICE POSITION

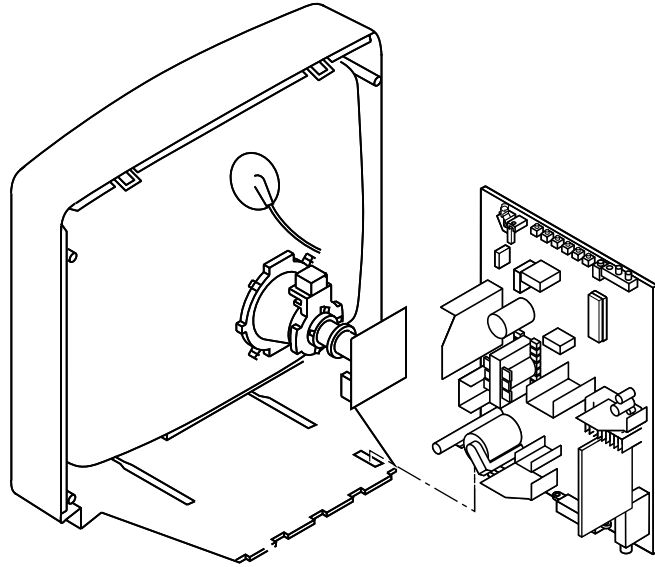

2-4. S1 BOARD REMOVAL

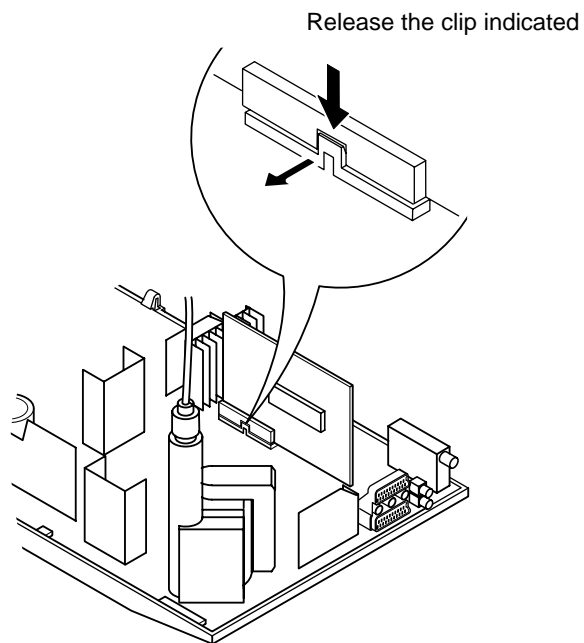

2-5. PICTURE TUBE REMOVAL

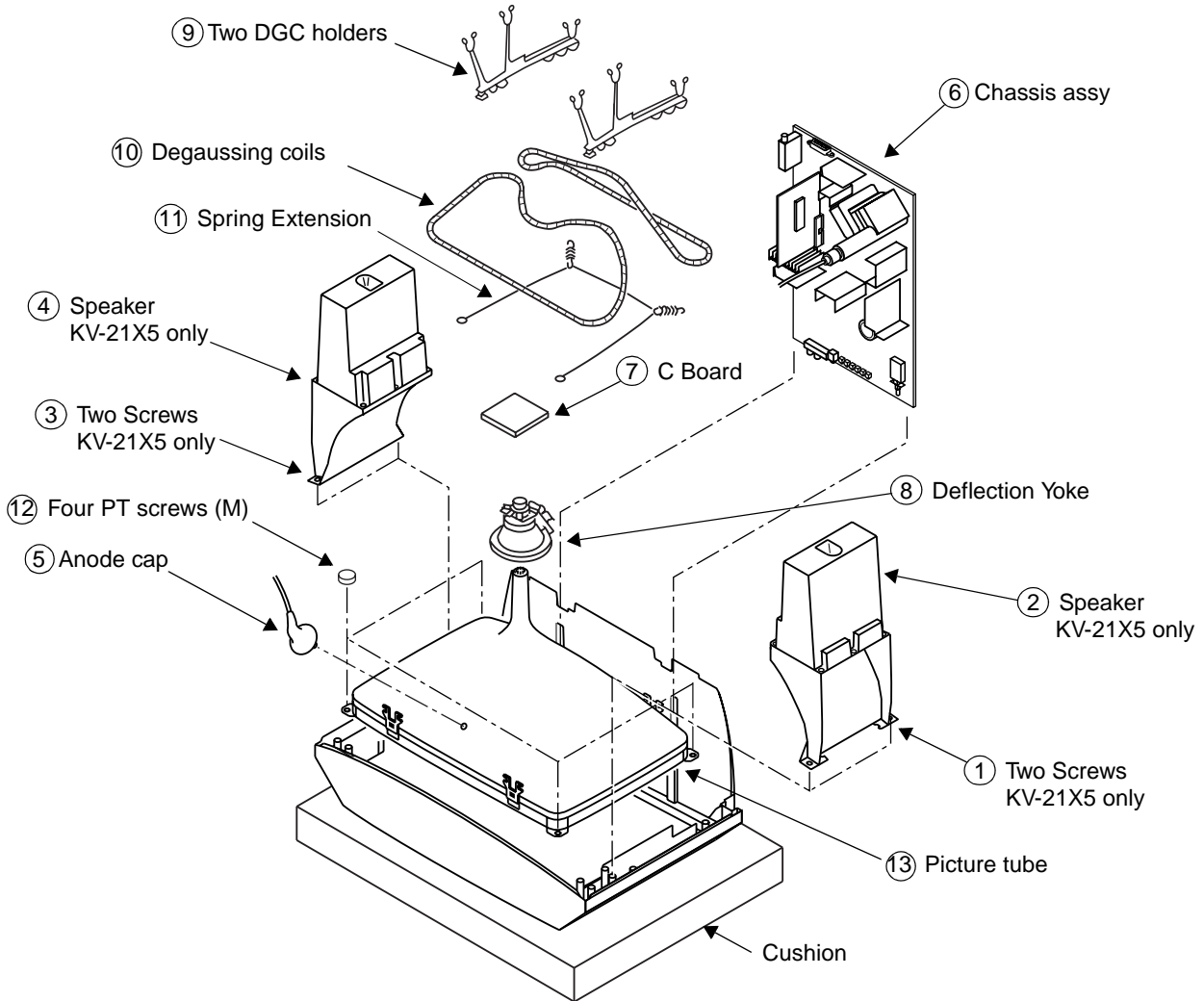

• REMOVAL OF ANODE-CAP

Note : Short circuit the anode of the picture tube and the anode cap to the metal chassis, CRT shield or carbon paint on the CRT, after removing the anode.

* REMOVING PROCEDURES.

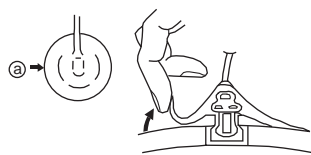

① Turn up one side of the rubber cap in the direction indicated by the arrow (a)

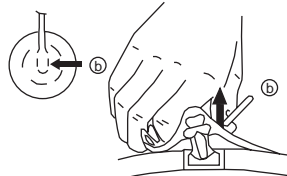

② Using a thumb pull up the rubber cap firmly in the direction indicated by the arrow (b)

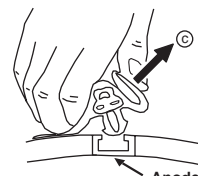

③ When one side of the rubber cap is separated from the anode button, the anode-cap can be removed by turning up the rubber cap and pulling it up in the direction of the arrow (c)

• HOW TO HANDLE THE ANODE-CAP

- ① To prevent damaging the surface of the anode-cap do not use sharp materials.
- ② Do not apply too great a pressure on the rubber, as this may cause damage to the anode connector.
- ③ A metal fitting called a shatter hook terminal is fitted inside the rubber cap. Do not turn the rubber foot over excessively this may cause damage if the shatter hook sticks out.

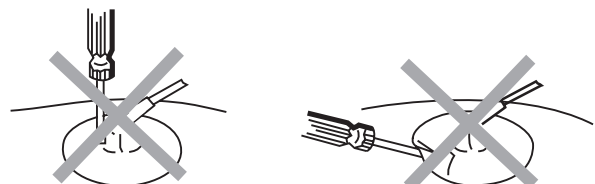

REMOVAL AND REPLACEMENT OF THE MAIN-BRACKET BOTTOM PLATES.

(1) REMOVING THE PLATES

In the event of servicing being required to the solder side of the A Board printed wiring board, the bottom plates fitted to the main chassis bracket require to be removed.

This is performed by cutting the gates with a sharp wire cutter at the locations shown and indicated by arrows.

Note : There are 2 plates fitted to the main bracket and secured by 4 gates.
Only remove the necessary plate to gain access to the printed wiring board.

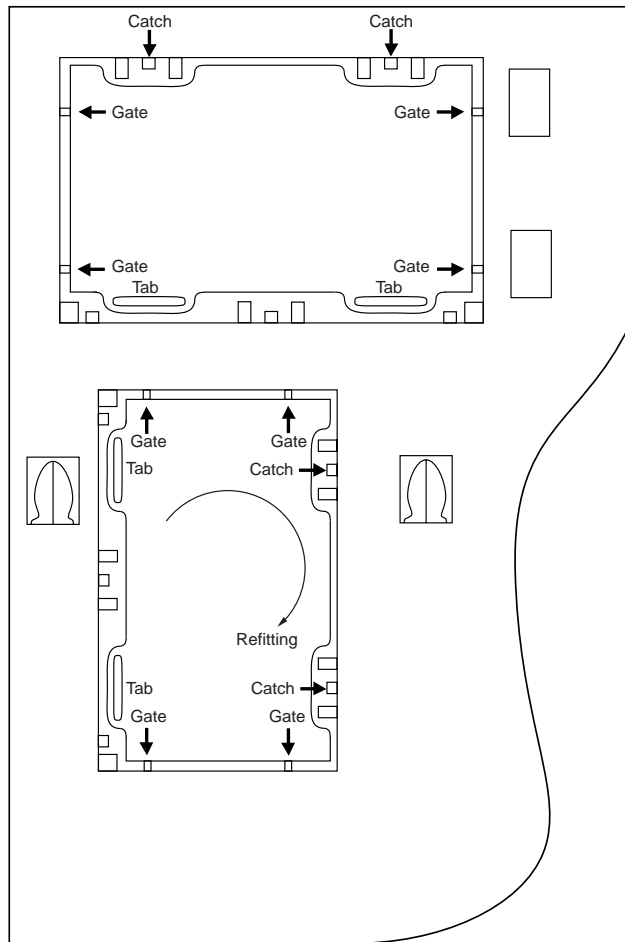

For safety reasons, on no account should the plates be removed and not refitted after servicing.

(2) REFITTING THE PLATES

Because the plates differ in size it is important that the correct plates are refitted in their original location.

Please note that the plates need to be rotated 180 degrees from the cut position to allow the tabs to be fitted in the catch positions.

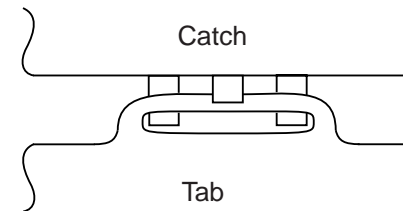

SECTION 3 SET-UP ADJUSTMENTS

- When complete readjustment is necessary or a new picture tube is installed, carry out the following adjustments.
- Unless there are specific instructions to the contrary, carry out these adjustments with the rated power supply.
- Unless there are specific instructions to the contrary, set the controls and switches to the following settings :

Contrast 80% [or remote control normal]
 Brightness 50%

Carry out the following adjustments in this order :

- 3-1. Beam Landing
- 3-2. Convergence
- 3-3. White balance
- 3-4. Focus

- Note :** Test equipment required
1. Color bar/pattern generator.
 2. Degausser.
 3. Oscilloscope.
 4. Digital multimeter.
 5. DC Power supply.

Preparation:

1. In order to reduce the influence of geomagnetism on the set's picture tube, face it in an easterly or westerly direction.
2. Switch on the TV set's power and degauss with the degausser.

3-1. BEAM LANDING

1. Input an all-white signal from the pattern generator. Set the Contrast and Brightness to normal.
2. Set the pattern generator raster signal to all Red.
3. Move the deflection yolk forward and adjust with the purity control so that the Red is at the centre and the Blue and Green take up equally sized areas on each side of the screen. [See Fig.3-1 - 3-3].
4. Move the deflection yolk forward and adjust so that the entire screen becomes Red. [See Fig.3-1].
5. Switch the raster signal to Blue, then to Green and verify the purity condition.
6. When the position of the deflection yolk has been determined, fasten the deflection yolk with the screws.
7. If the beam does not land correctly in all the corners, use magnets to correct it. [See Fig.3-4].

Fig. 3-2

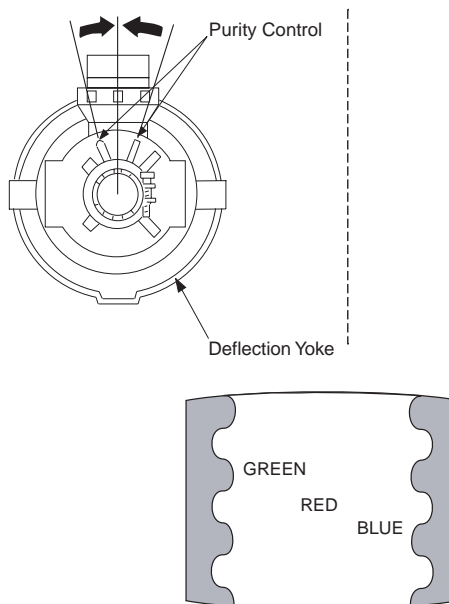

Fig. 3-3

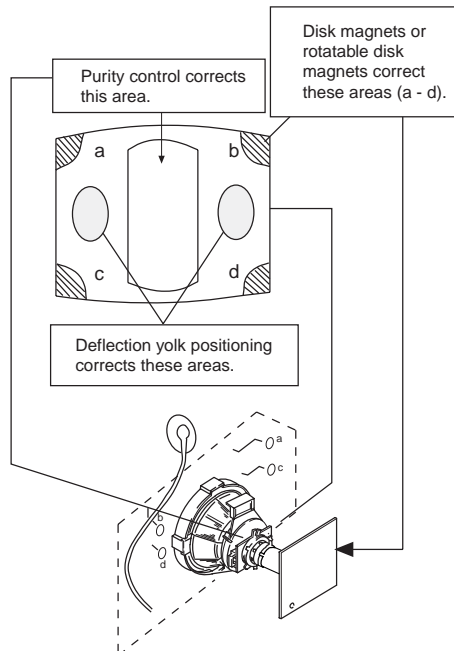

Fig. 3-4

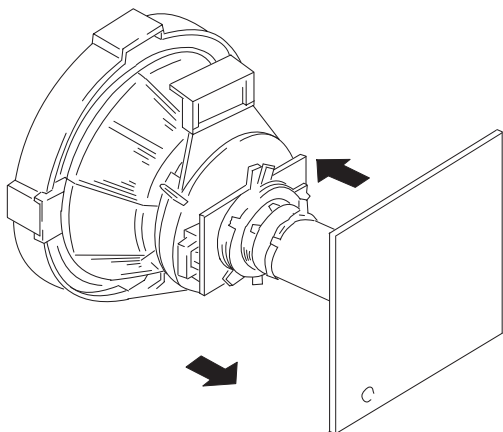

Fig. 3-1

3-2. CONVERGENCE

Preparation:

- Before starting this adjustment, adjust the focus, horizontal size and vertical size.
- Minimize the Brightness setting.
- Input a dot pattern from the pattern generator.

(1) Horizontal and vertical static convergence

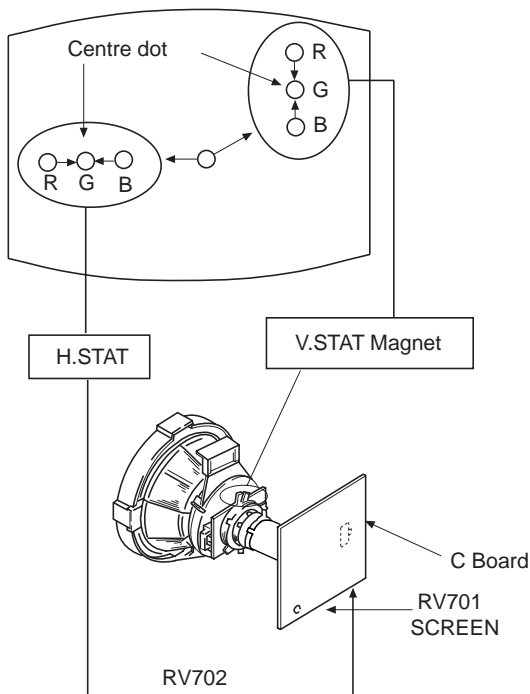

1. [Moving horizontally], adjust the H.STAT control so that the Red, Green and Blue points are on top of each other at the centre of the screen.
2. [Moving vertically], adjust the V.STAT magnet so that the Red, Green and Blue points are on top of each other at the centre of the screen.
3. If the H.STAT variable resistor is unable to bring the Red, Green and Blue points together at the centre of the screen, adjust the horizontal convergence with the H.STAT variable resistor and the V.STAT magnet in the manner indicated below. [In this case, the H.STAT variable resistor and the V.STAT magnet influence each other].

- Tilt the V.STAT magnet and adjust the static convergence by opening or closing the V.STAT magnet.

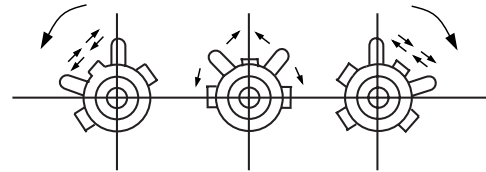

4. If the V.STAT magnet is moved in the direction of the (a) and (b) arrows, the Red, Green and Blue points move as indicated below.

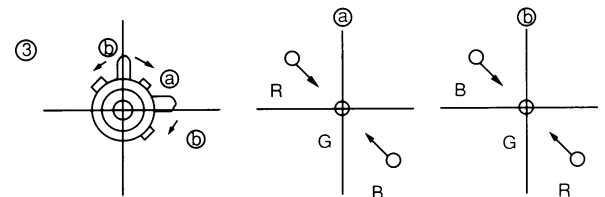
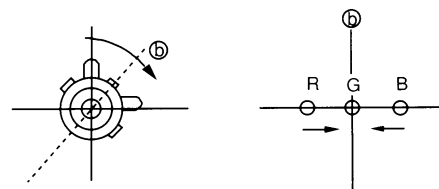
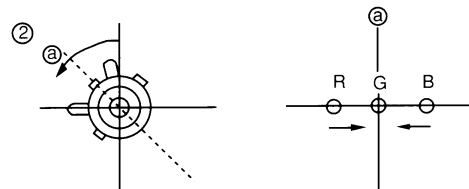
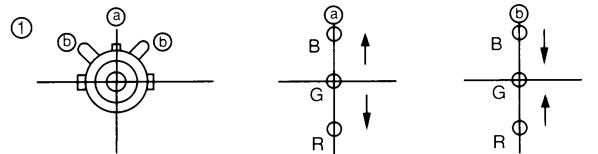

(2) Operation of the BMC (Hexapole) magnet.

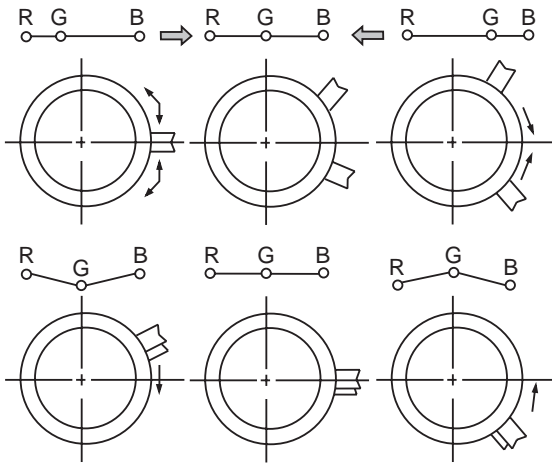

- The respective dot position resulting from moving each magnet interact, so be sure to perform adjustment whilst tracking.
Use the H.STAT VR to adjust the Red, Green and Blue dots so that they coincide at the centre of the screen [by moving the dots in the horizontal direction].

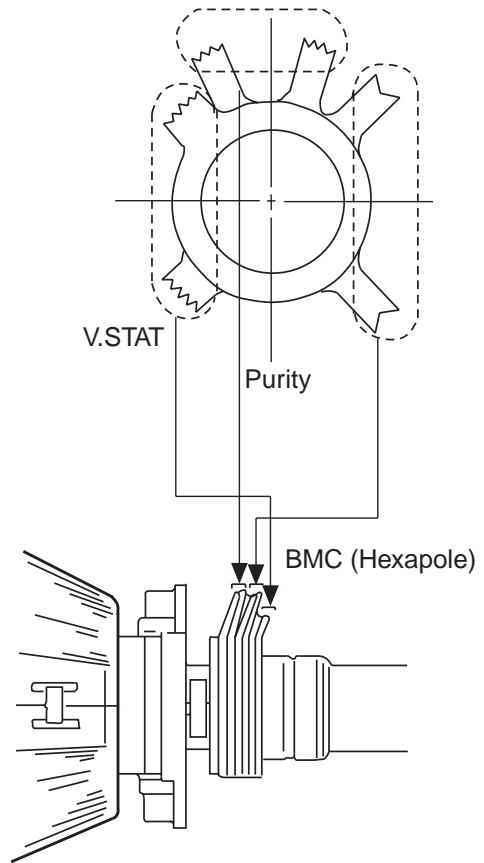

(3) Dynamic convergence adjustment.

Preparation:

- Before starting this adjustment, adjust the horizontal and vertical static convergence.
- Slightly loosen the deflection yolk screws.
 - Remove the deflection yolk spacer.
 - Move the deflection yolk as indicated in the figure below and optimize the convergence.
 - Tighten the deflection yolk screws.
 - Re-install the deflection yolk spacer.

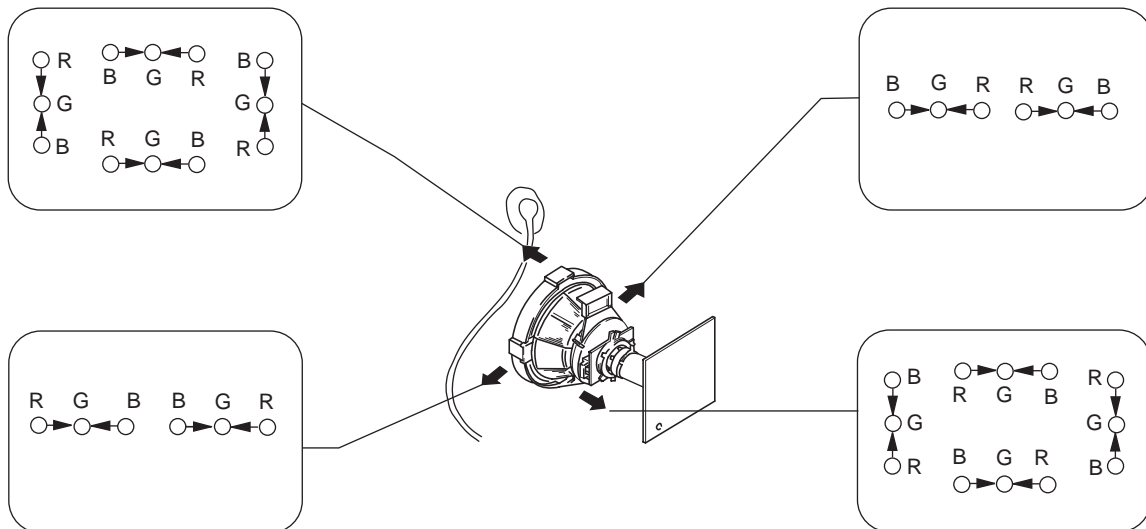

(4) Screen corner convergence.

- If you are unable to adjust the corner convergence properly, this can be corrected by the use of permalloy assemblies.

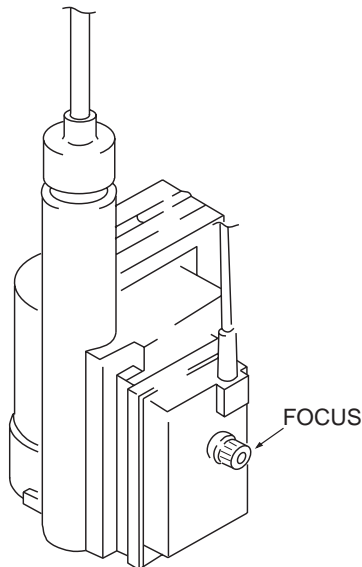
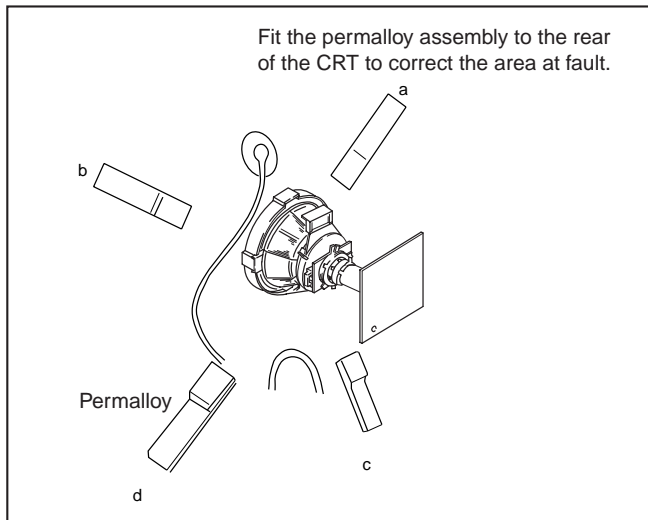
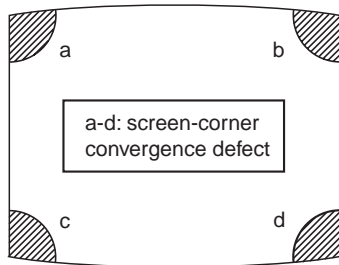

3-3. Screen [G2], White balance

G2 Setting

- Input a dot signal from the pattern generator.
- Set the Picture, Brightness and Colour to minimum.
- Apply 170Vdc from an external power supply to the R, G and B cathodes of the CRT.
- Whilst watching the picture, adjust the G2 control [RV701 SCREEN] located on the C Board to the point just before the flyback return lines disappear.

White balance adjustment

- Input a 'PAL' all-white signal from the pattern generator.
- Enter into the Service Mode.
- Enter into the 'Picture' service menu.
- Select the 'Green drive' and adjust so that the White Balance becomes optimum.
- Select the 'Blue drive' and adjust so that the White Balance becomes optimum.
- Set the Picture to MIN.
- Set the 'R-cut-off' to 07.
- Adjust the 'G-cut-off', and the 'B-cut-off' so that the White Balance becomes optimum.
- Press the button to return to TV operation.

PICTURE	
R - Drive	Adj
G - Drive	Adj
B - Drive	Adj
R - cut - off	Adj
G - cut - off	Adj
B - cut - off	Adj
ID - start	02
ID - stop	01
ID - level	01
Bellfo	Adj
Sub Colour	Adj
Sub Brightness	Adj

3-4. FOCUS

- Input a Phillips colour pattern
- Set the picture settings to normal.
- Adjust the focus control located on the Flyback transformer to bring the centre of the screen into focus.

Note :Bring only the centre area of the screen into focus, switch to an all-white pattern and confirm that the magenta ring is hardly noticed. To obtain optimum focus balance the focus setting between optimum screen centre focus and a reduced magenta ring level.

SECTION 4 CIRCUIT ADJUSTMENTS

4-1. ELECTRICAL ADJUSTMENTS

Service adjustments to this model can be performed using the supplied Remote Commander RM-883.

HOW TO ENTER INTO SERVICE MODE

1. Turn on the main power switch and enter into the stand-by mode.
2. Press the following sequence of buttons on the Remote Commander.

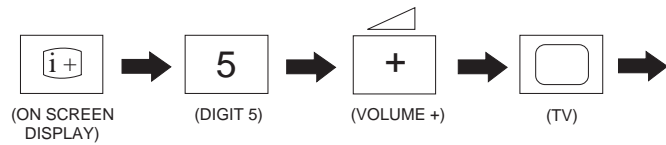

- 'TT--' will appear in the upper right corner of the screen. Other status information will also be displayed.
3. Press 'MENU' on the remote commander to obtain the following menu on the screen.

TEST MENU
> Picture
Geometry
Sound
TV Status
AGC Adjust
Technical

4. Move to the corresponding adjustment item using the 'Green' [up] or 'Blue' [down] buttons on the Remote Commander.
5. Press the 'Yellow' button to enter into the required menu item.
6. Press the 'Menu' button on the Remote Commander to quit the Service Mode when all adjustments have been completed.

Note :The data shown in the 'TV STATUS' table is dependant on destination and country.

PICTURE

R - Drive	Adj
G - Drive	Adj
B - Drive	Adj
R - cut - off	Adj
G - cut - off	Adj
B - cut - off	Adj
ID - start	02
ID - stop	01
ID - level	01
Bell-f0	Adj
Sub Colour	Adj
Sub Brightness	Adj

GEOMETRY

V centre	Adj
V size	Adj
V Lin	Adj
S Corr	Adj
H Cent	Adj
H Size	Adj
Pin Amp	Adj
Corner Pin	Adj
Pin Phase	Adj
V Bow	Adj
V Angle	Adj
Upper V Lin	Adj
Lower V Lin	Adj
Left HBLK	07
Right HBLK	07
CD Mode (AV)	01

SOUND

Nicam Error Lower	20
Nicam Error Upper	80
Nicam Error Rate	xx [Status only]
AGC Gain Level	xx [Status only]

TV STATUS

Destination	A/L/E/U/D/B/K/R
Text Language	East/West

TECHNICAL	
GD - Secam	30
BD - Secam	31
RC - Secam	11
GC - Secam	19
BC - Secam	10
GD - Sports	30
BD - Sports	36
RC - Sports	14
GC - Sports	15
BC - Sports	17
Y - Delay (AV)	07

SUB BRIGHTNESS ADJUSTMENT

1. Input a Phillips colour pattern.
2. Press 'TEST' 'TEST' 13 on the Remote Commander.
3. Adjust the 'Sub-Brightness' data so that there is barely a difference between the 0 IRE and 10 IRE signal levels.

SUB CONTRAST ADJUSTMENT

1. Input a video signal that contains a small 100% white area on a black background
2. Set the picture control to maximum. ['TT01']
3. Connect an oscilloscope to Pin 1 of CN504 [A Board].
4. Enter into the 'Picture' service menu.
5. Adjust the 'R - Drive' data to obtain the following waveform.

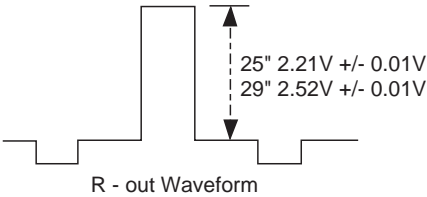

SUB COLOUR ADJUSTMENT

1. Receive a PAL colour bar signal.
2. Connect an oscilloscope to Pin 3 of CN504 [A Board].
3. Enter into the 'Picture' service menu.
4. Adjust the 'Sub Colour' data so that the Cyan, Magenta and Blue colour bars are of equal levels as indicated below.

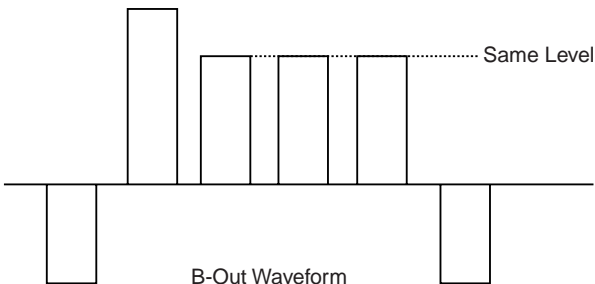

Note: Ensure that no signal is applied to the Antenna socket while carrying out the following IF adjustments.

SYSTEM B/G, D/K, I & L I.F ADJUSTMENT

1. Input a 38.9Mhz carrier signal at 100dBuV to Pin 11 [IF output] of the tuner [TU101].
2. Measure the voltage at Pin 17 of [IC101].
3. Adjust L103 [A Board] to obtain a voltage of 2.5V +/- 0.3V.

SYSTEM L BAND 1 I.F ADJUSTMENT

1. Input a 34.0MHz carrier signal at 100dBuV to Pin 11 [IF output] of the tuner [TU101].
2. Select 'system L' + C00 [channel 00].
3. Measure the voltage at Pin 17 [IC101].
4. Adjust RV101 [A Board] to obtain a voltage of 2.5V +/- 0.3V.

TUNER AGC ADJUSTMENT

1. Receive a signal of 65dBuV / 75 ohm terminated, via the tuner antenna socket.
2. Connect a voltmeter to JW130 [A Board].
3. Enter into the 'Test Menu'.
4. Select the 'AGC Adjust' menu item.
5. Adjust the data using the Yellow and Green buttons on the Remote Commander to obtain a voltage of 3.0V +/- 0.2V.

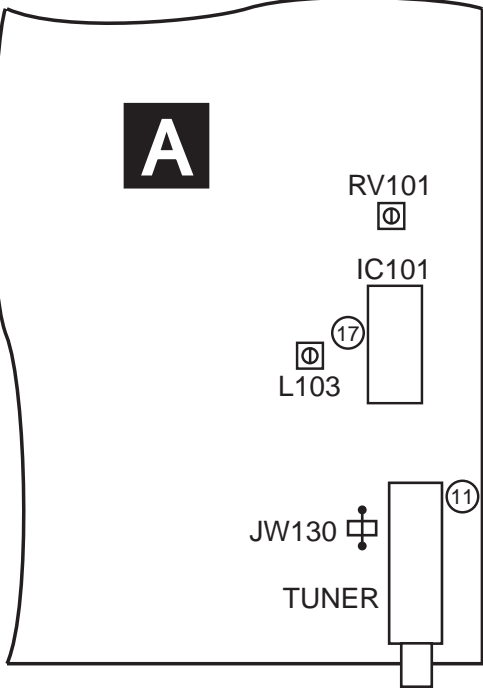

A Board component side

BELL FILTER ADJUSTMENT (Secam models only).

Note : Ensure that the TV set has been powered up for at least 1 minute to allow for drift before carrying out the following adjustment.

1. Input a video SECAM Colour Bar signal via AV1.
2. Connect an oscilloscope to pin 1 of CN504 [R-OUT] on the A board.
3. Enter into the 'Picture' menu and select 'Bell-f0'.
4. Decrease the register of 'Bell-f0' until the following waveform change between RED and BLUE is obtained.

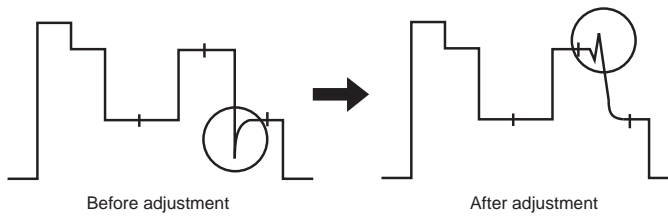

5. When the correct waveform has been obtained add an additional 7 steps to the register.

DEFLECTION SYSTEM ADJUSTMENT

1. Enter into the 'Geometry' service menu.
2. Select and adjust each item in order to obtain the optimum image.

GEOMETRY

V centre	Adj
V size	Adj
V Lin	Adj
S Corr	Adj
H Cent	Adj
H Size	Adj
Pin Amp	Adj
Corner Pin	Adj
Pin Phase	Adj
V Bow	Adj
V Angle	Adj
Upper V Lin	Adj
Lower V Lin	Adj
Left HBLK	07
Right HBLK	07
CD Mode (AV)	01

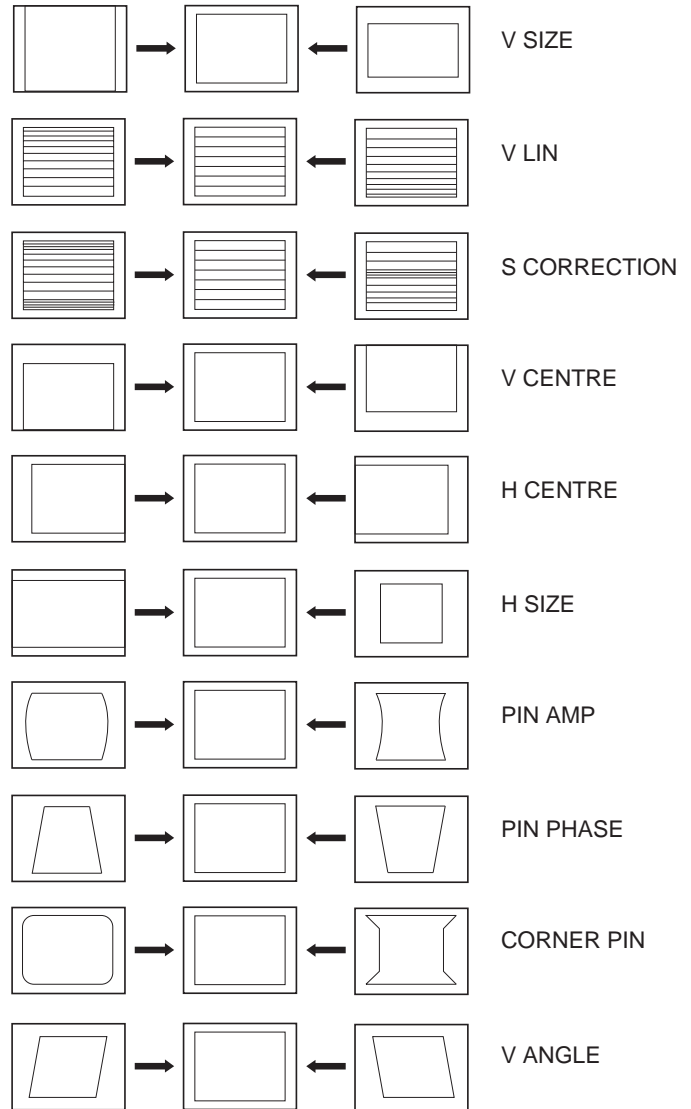

4-2. TEST MODE 2:

Is available by pressing 'TEST' button twice, OSD 'TT' appears. The functions described below are available by pressing the two numbers. To release the Test mode 2, press 0 twice, or switch the TV into stand-by mode, or press the TV button on the remote commander.

00	Cancel Test mode
01	Picture maximum
02	Picture minimum
03	Volume 35%
04	Volume 50%
05	Volume 65%
06	Volume 80%
07	Ageing mode On/Off
08	Set shipping conditions
09	Display TV Status
10	No function
11	Sub Picture Adjustment
12	Sub Colour Adjustment
13	Sub Brightness Adjustment
14	Text H position Adjustment
15	Rotation test
16	Picture level 50%
17	Audio mute ON
18	Disable Blanking
19	No function
20	No function
21	Destination A
22	Destination L
23	Destination E
24	Destination U
25	Destination D
26	Destination B
27	Destination K
28	Destination R
29	No function
30	No function
31	Auto shutoff Disable/Enable
32	RGB priority Disable/Enable
33	Rotation On/OFF
34	Text language East/West
35	Wide CRT/4:3 CRT
36	VM ON/OFF test
37	No function
38	No function
39	No function
40	No function
41	Re-initialize the NVM [Only when Prog=59]

42	Re-initialise geometry settings [Only when Prog=59]
43	No function
44	No function
45	No function
46	No function
47	No function
48	Set NVM as NON Virgin [Only when Prog=59]
49	Set NVM as Virgin [Only when Prog=59]
50	No function
51	No function
52	No function
53	No function
54	No function
55	No function
56	No function
57	No function
58	No function
59	No function
60	No function
61	Auto AGC Adjust
62	Alternative Dest B Autotuning
63	Enable/Disable Y/C input
64	Signal Quality Check for Auto Tune
65	Signal Quality NOT Checked for Auto Tune
66	No function
67	Manual AGC Adjust
68 -100	No function

4-3. FE-1 SELF DIAGNOSTIC SOFTWARE

The identification of errors within the FE-1 chassis is triggered in one of two ways :- 1: Busy or 2: Device failure to respond to IIC. In the event of one of these situations arising the software will first try to release the bus if busy (Failure to do so will report with continuous flashing LED) and then communicate with each device in turn to establish if a device is faulty. If a device is found to be faulty the relevant device number will be displayed through the LED (Series of flashes which must be counted) See Table 1., non fatal errors are reported using this method. Each time the software detects an error it is stored within the NVM. See Table 2.

Table 1

ERROR	LED ERROR COUNT
No error	00
Not allowed (may be confused with Sircs response flash!)	01
Protection circuit trip < ANY TIME >	02
Reserved	03
No vertical sync	04
AKB	05
IIC bus clock and/or data lines low at Power ON	06
NVM no IIC bus acknowledge at Power ON	07
Jungle controller no IIC acknowledge at Power ON	08
Tuner no acknowledge at Power ON	09
Sound processor no acknowledge at Power ON	10

Flash Timing Example : e.g. error number 3

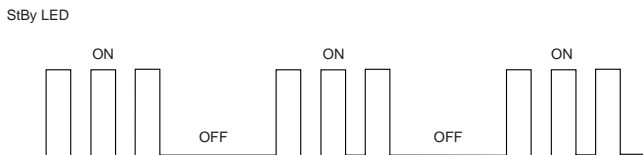

How to enter into Table 2

1. Turn on the main power switch of the TV set and enter into the 'Standby Mode'.
2. Press the following sequence of buttons on the Remote Commander.

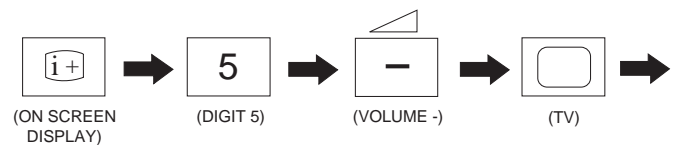

3. The following table will be displayed indicating the error count.

Table 2

Error	Times
2	-
3	-
4	-
5	-
6	-
7	-
8	-
9	-
10	-

Note: To clear the error count data press '80' on the Remote commander.

5-1 BLOCK DIAGRAMS

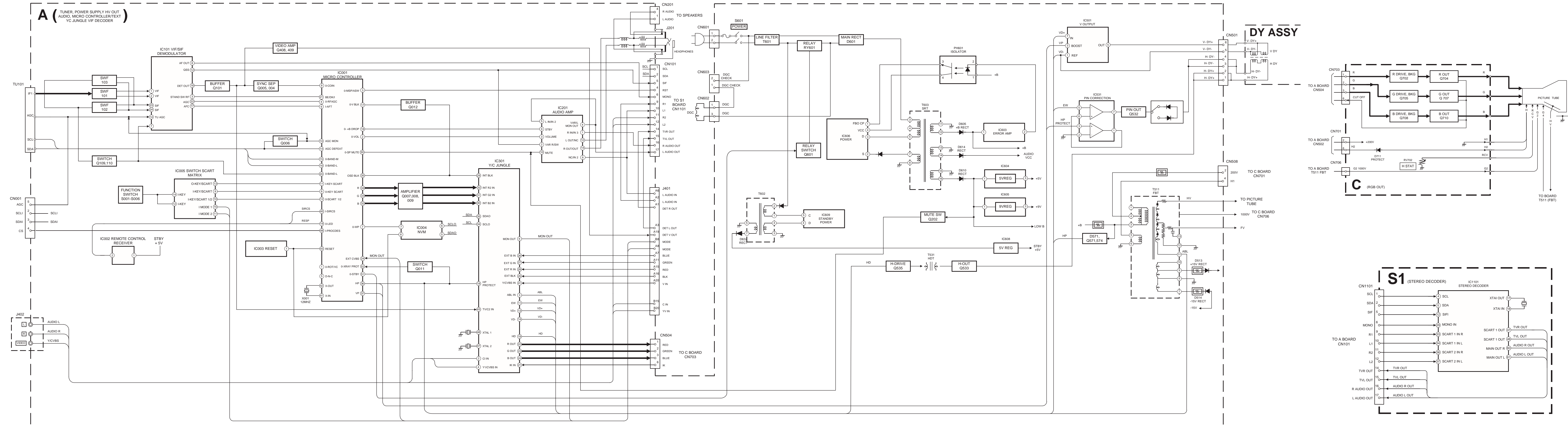

5-2. CIRCUIT BOARD LOCATION

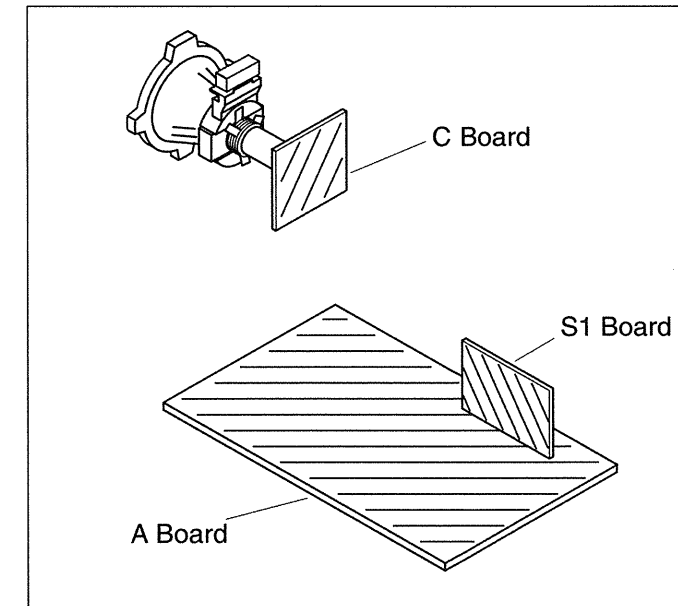

5-3. SCHEMATIC DIAGRAMS AND PRINTED WIRING BOARDS

Note :

- All capacitors are in μF unless otherwise noted.
- μF : μF 50WV or less are not indicated except for electrolytic types.
- Indication of resistance, which does not have one for rating electrical power, is as follows.

Pitch : 5mm
Electrical power rating : 1/4W

- Chip resistors are 1/10W
- All resistors are in ohms.
- k = 1000 ohms, M = 1000,000 ohms

- : nonflammable resistor.
- : fusible resistor.
- : internal component.
- : panel designation or adjustment for repair.

- All variable and adjustable resistors have characteristic curve B, unless otherwise noted.
- All voltages are in Volts.
- Readings are taken with a 10Mohm digital multimeter.
- Readings are taken with a color bar input signal.
- Voltage variations may be noted due to normal production tolerances.

- : B + bus.
- : B - bus.
- : RF signal path.
- : earth - ground.
- : earth - chassis.

Reference Information

RESISTOR	RN	: METAL FILM
	RC	: SOLID
	FPRD	: NON FLAMMABLE CARBON
	FUSE	: NON FLAMMABLE FUSIBLE
	RS	: NON FLAMMABLE METAL OXIDE
	RB	: NON FLAMMABLE CEMENT
	RW	: NON FLAMMABLE WIREWOUND
		: ADJUSTMENT RESISTOR
COIL	LF-8L	: MICRO INDUCTOR
CAPACITOR	TA	: TANTALUM
	PS	: STYROL
	PP	: POLYPROPYLENE
	PT	: MYLAR
	MPS	: METALIZED POLYESTER
	MPP	: METALIZED POLYPROPYLENE
	ALB	: BIPOLAR
	ALT	: HIGH TEMPERATURE
	ALR	: HIGH RIPPLE

Note : The components identified by shading and marked Δ are critical for safety. Replace only with the part numbers specified in the parts list.

Note : Les composants identifiés par une trame et par une marque Δ sont d'une importance critique pour la sécurité. Ne les remplacer que par des pièces de numéro spécifié.

A [POWER SUPPLY, DEFLECTION, TUNING, PROCESSOR, VIDEO SIGNAL PROCESSOR, AV IN/OUT]

A Board

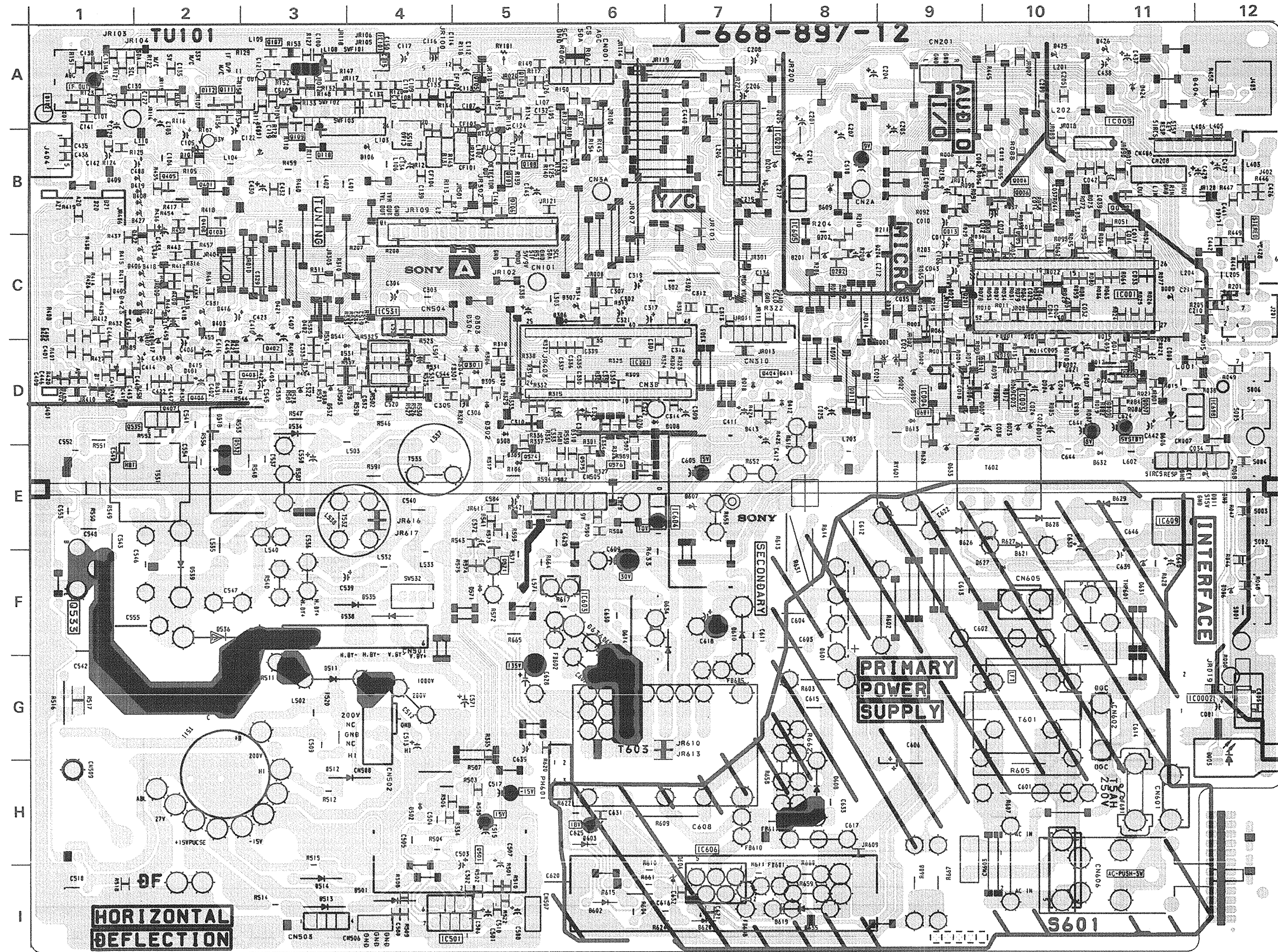

A BOARD

IC	Q574	E - 5	D420	C - 1
IC001	Q575	E - 6	D423	C - 1
IC002	Q576	E - 6	D424	A - 11
IC003	Q601	D - 9	D427	B - 2
IC004			D501	I - 4
IC005			D502	H - 4
IC101			D512	H - 3
IC201			D513	I - 3
IC301			D514	I - 3
IC501			D534	D - 3
IC531			D535	F - 4
IC603			D536	F - 2
IC604			D538	F - 4
IC605			D539	F - 2
IC606			D541	D - 3
IC608			D571	F - 5
IC609			D573	D - 3
DIODE				
Q004	D001	D - 9	D601	G - 8
Q005	D002	D - 8	D602	I - 6
Q006	D003	H - 12	D603	H - 6
Q007	D004	D - 10	D605	G - 6
Q008	D005	D - 9	D608	H - 8
Q009	D007	D - 10	D610	F - 7
Q010	D008	D - 7	D613	E - 9
Q011	D010	D - 10	D614	G - 6
Q012	D011	E - 12	D619	I - 8
Q014	D012	D - 11	D621	F - 10
Q101	D015	D - 11	D626	F - 9
Q107	D017	D - 10	D627	F - 9
Q109	D018	D - 7	D628	E - 10
Q110	D023	E - 10	D629	E - 11
Q202	D101	B - 2	D631	F - 11
Q401	D102	C - 8	D632	E - 11
Q405	D103	C - 8	D633	E - 9
Q408	D104	D - 11	D627	F - 9
Q501	D105	D - 10		
Q532	D106	D - 7		
Q533	D107	B - 2		
Q535	D108	B - 7		
Q571	D109	C - 6		
	D110	E - 5		
	D111	D - 6		
	D112	C - 2		
	D113	C - 1		
	D114	D - 2		
	D115	C - 1		
	D116	B - 1		
	D117	C - 3		
	D118	D - 2		
	D119	D - 2		
	D120	C - 1		
	D121	B - 1		

NOTE:
The circuit indicated as left contains high voltage of over 600 Vp-p. Care must be paid to prevent an electric shock in inspection or repairing.

A BOARD IC VOLTAGE TABLE

IC Voltage Table								
Ref No	Pin No	Voltage (V)	Ref No	Pin No	Voltage (V)	Ref No	Pin No	Voltage (V)
IC001	4	0.8	IC101	5	2.8	IC301	20	3.8
	6	3.2		6	2.7		21	1.6
	7 - 8	4.8		7	3.9		22 - 24	1.5
	9	0.3		8	2.2		26 - 28	4.5
	10	2.0		12	2.0		30	4.5
	11	1.5		15	1.5		31 - 32	4.4
	12	4.7		17	0.3		33	8.1
	19	3.6		18 - 19	2.6		34 - 35	3.3
	20	4.3		21	4.7		41	5.0
	21	4.8		22	0.9		42	8.6
	24	2.5		23 - 24	3.2		43	5.0
	25	2.1		1	15.3		44	8.8
	26	2.4	5	15.3	45	5.2		
	30	4.8	7	15.3	48	1.5		
	31	5.0	10	4.5	1	1.4		
	36	0.2	12	15.3	2	14.0		
	37	0.1	13	31.2	3	-13.0		
	38 - 39	5.0	14	15.3	4	-14.0		
	41 - 42	2.2	1	3.3	5	0.2		
	44	4.8	2	5.0	6	14.5		
	45	2.8	3	4.3	7	1.4		
	47	0.1	4	5.0	1	1.6		
	48	2.4	6	4.4	2	1.7		
	49	3.3	8	4.5	3	1.9		
50	3.1	11	3.9	5	2.8			
51	0.1	12	2.4	6	2.0			
IC004	5 - 6	4.8	13	3.5	7	7.3		
	7	3.3	14	3.4	8	8.8		
	8	3.2	15	5.6	1 - 2	-60.0		
IC101	1 - 2	3.2	16	7.6	4	-51.3		
	3	4.8	18	1.3	IC609	4	-58.0	
	4	3.0	19	2.4				

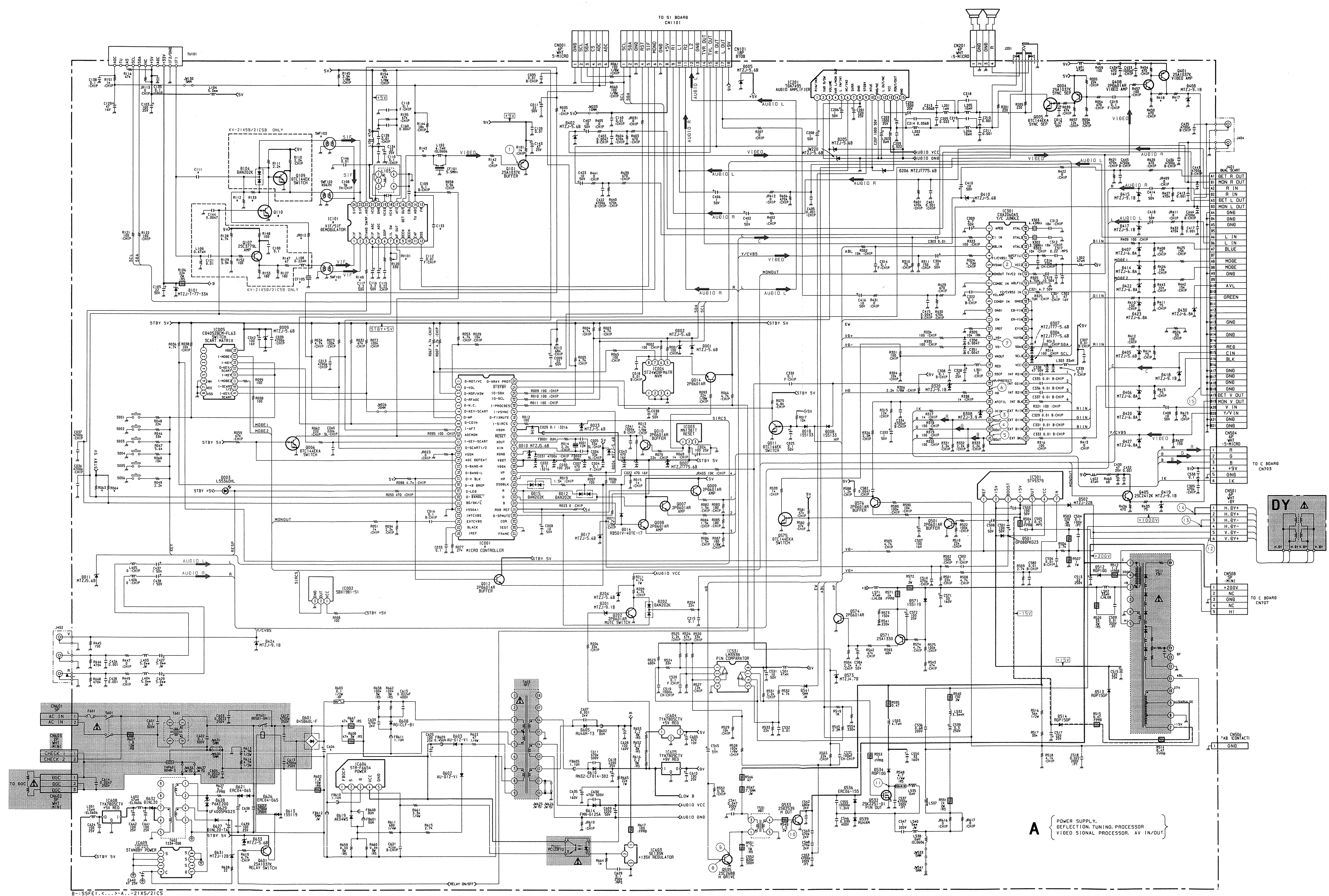

WAVEFORMS A BOARD

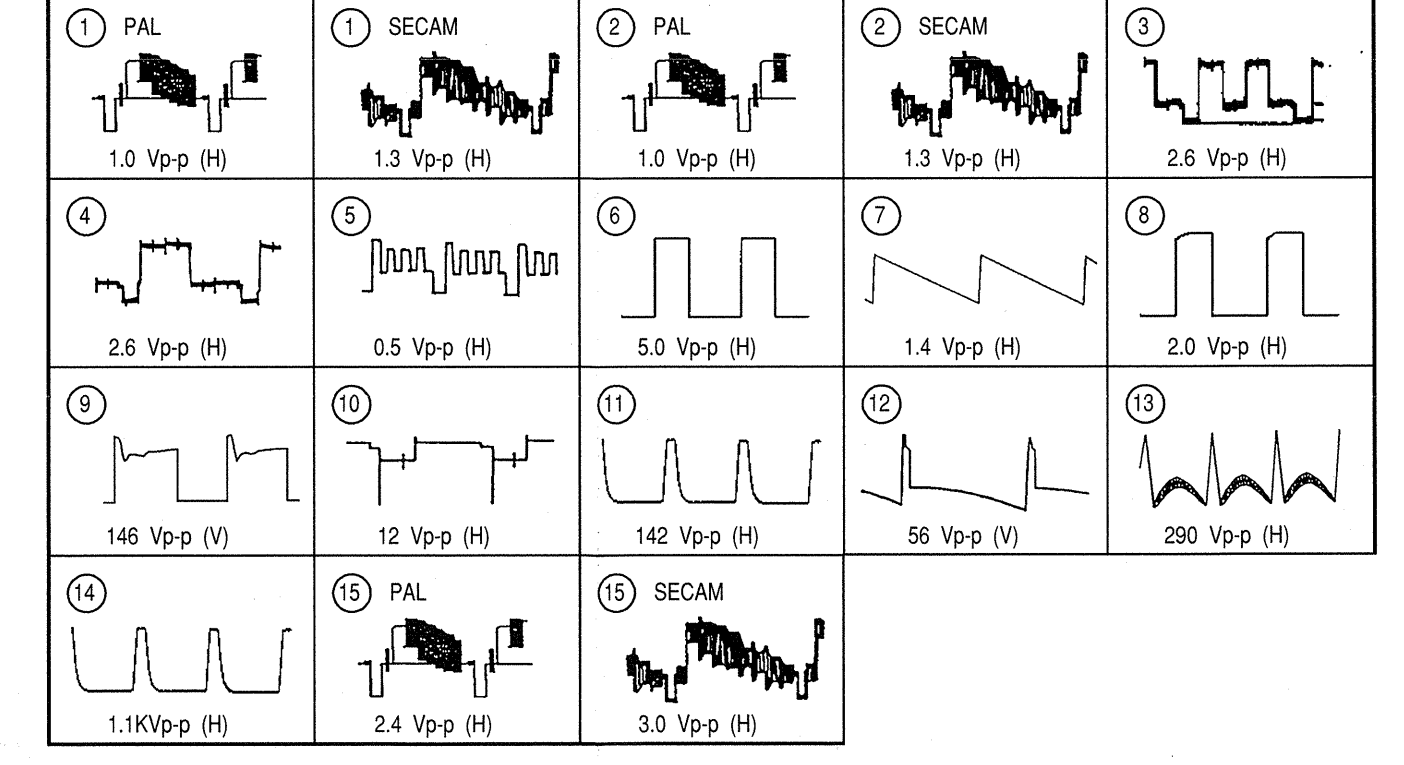

A BOARD TRANSISTOR VOLTAGE TABLE

Transistor Voltage Table				
Ref No	(B) Base	(C) Collector	(E) Emitter	
Q004	4.7	0.7	4.9	
Q005	0.3	4.8	-	
Q006	-	2.0	-	
Q007	-	4.9	-	
Q008	-	4.9	-	
Q009	-	4.9	-	
Q010	0.6	-	-	
Q011	0.5	-	-	
Q012	-	4.8	-	
Q101	2.0	-	2.6	
Q109	-	4.7	-	
Q110	4.3	-	-	
Q202	0.6	-	-	
Q401	8.0	3.4	8.6	
Q408	2.6	8.0	2.0	
Q532	7.3	3.1	-	
Q533	-0.2	-152.0	-	
Q535	-0.7	92.0	-	
Q571	134.2	-	134.4	
Q574	-	2.0	-	
Q576	3.4	6.7	2.8	
Q601	4.0	3.6	4.8	

A BOARD MARK

Ref	21CSB	21CSD	21CSE	21CSK	21CSR	21X5A	21X5B	21X5D	21X5E	21X5K	21X5L	21X5R	21X5U
C111	0.01MF	SHORT 0	SHORT 0	SHORT 0	SHORT 0	SHORT 0	0.01MF	SHORT 0	SHORT 0	SHORT 0	SHORT 0	SHORT 0	SHORT 0
C133	1MF	-	-	-	-	-	1MF	-	-	-	-	-	-
C218	0.001MF	-	-	-	-	-	0.001MF	-	-	-	-	-	-
C219	0.001MF	-	-	-	-	-	0.001MF	-	-	-	-	-	-
C506	220MF 400V	220MF 400V	220MF 400V	220MF 450V	220MF 450V	220MF 400V	220MF 400V	220MF 400V	220MF 400V	220MF 450V	220MF 450V	220MF 450V	220MF 400V
C638	10MF 400V	10MF 400V	10MF 400V	10MF 400V	10MF 450V	10MF 400V	10MF 400V	10MF 400V	10MF 400V	10MF 400V	10MF 400V	10MF 450V	10MF 400V
CF105	TRAP CERAMIC	TRAP CERAMIC	TRAP CERAMIC	TRAP CERAMIC	TRAP CERAMIC	TRAP CERAMIC	TRAP CERAMIC	TRAP CERAMIC	TRAP CERAMIC	TRAP CERAMIC	TRAP CERAMIC	TRAP CERAMIC	TRAP CERAMIC
IC001	SAA5497PS/M1A074	SAA5497PS/M1A074	SAA5497PS/M1A074	SAA5497PS/M1A074	SAA5497PS/M1A075	SAA5497PS/M1A076	SAA5497PS/M1A074	SAA5497PS/M1A074	SAA5497PS/M1A074	SAA5497PS/M1A074	SAA5497PS/M1A074	SAA5497PS/M1A075	SAA5497PS/M1A074
IC101	TD9818V1	TD9817V1	TD9817V1	TD9817V1	TD9817V1	TD9817V1	TD9818V1	TD9817V1	TD9817V1	TD9817V1	TD9817V1	TD9817V1	TD9817V1
JR102	-	SHORT 0	SHORT 0	SHORT 0	SHORT 0	SHORT 0	-	SHORT 0	SHORT 0	SHORT 0	SHORT 0	SHORT 0	SHORT 0
Q110	DTC144EKA	-	-	-	-	-	DTC144EKA	-	-	-	-	-	-
R083	4.7K	-	-	-	-	-	4.7K	-	-	-	-	-	-
R084	4.7K	-	-	-	-	-	4.7K	-	-	-	-	-	-
R112	2.2K	-	-	-	-	-	2.2K	-	-	-	-	-	-
R133	-	SHORT 0	SHORT 0	SHORT 0	SHORT 0	SHORT 0	-	SHORT 0	SHORT 0	SHORT 0	SHORT 0	SHORT 0	SHORT 0
R143	100	180	180	180	180	180	100	180	180	180	180	180	180
R149	1K	-	-	-	-	-	1K	-	-	-	-	-	-
R417	75	75	75	75	75	75	75	75	75	68	75	68	68
R418	470	470	470	470	470	470	470	470	470	560	470	560	560
RW101	22K	-	-	-	-	-	22K	-	-	-	-	-	-
SWF101	1-579-273-11	1-767-874-11	1-767-874-11	1-767-874-11	1-767-874-11	1-767-874-11	1-579-273-11	1-767-874-11	1-767-874-11	1-767-874-11	1-579-273-11	1-767-874-11	1-579-273-11
SWF103	1-767-083-11	-	-	-	-	-	1-767-083-11	-	-	-	-	-	-
TU101	TELE9-001A	FSS BTP-AC411	FSS BTP-AC411	FSS BTP-AC411	FSS BTP-AC411	FSS BTP-AC411	TELE9-001A	FSS BTP-AC411	FSS BTP-AC411	FSS BTP-AC411	FSS BTP-AC411	FSS BTP-AC411	FSS BTP-AC411

S1 BOARD * MARK

Ref	21CSB	21CSD	21CSE	21CSK	21CSR	21XSA	21XSB	21XSD	21XSE	21XSK	21XSL	21XSR	21XSU
C1127	33PF	22PF	33PF	33PF	22PF	22PF	33PF	22PF	33PF	33PF	22PF	22PF	33PF
C1129	0.033MF	-	0.033MF	0.033MF	-	-	0.033MF	-	0.033MF	0.033MF	0.033MF	-	0.033MF
C1130	0.33MF	-	0.33MF	0.33MF	-	-	0.33MF	-	0.33MF	0.33MF	0.33MF	-	0.33MF
C1131	0.47MF	0.47MF	-	-	0.47MF	0.47MF	0.47MF	0.47MF	-	-	-	0.47MF	-
D1101	BB135	SHORT 0	BB135	BB135	SHORT 0	SHORT 0	BB135	SHORT 0	BB135	BB135	BB135	SHORT 0	BB135
FB113	4.7UH	-	-	-	4.7UH	-	4.7UH	-	-	-	-	-	-
IC1101	TDA9875P	TDA9870	TDA9875P	TDA9875P	TDA9870	TDA9870	TDA9875P	TDA9870	TDA9875P	TDA9875P	TDA9870	TDA9875P	TDA9875P
L1101	2.7UH	2.7UH	2.7UH	2.7UH	-	-	2.7UH	2.7UH	2.7UH	2.7UH	2.7UH	-	2.7UH
R1108	2.2K	-	-	-	2.2K	-	-	-	-	-	-	-	-
R1116	39K	SHORT 0	39K	39K	SHORT 0	SHORT 0	39K	SHORT 0	39K	39K	39K	SHORT 0	39K
R1117	10K	-	10K	10K	-	-	10K	-	10K	10K	10K	-	10K
R1118	39K	-	39K	39K	-	-	39K	-	39K	39K	39K	-	39K
R1164	10K	-	10K	10K	-	-	10K	-	10K	10K	10K	-	10K
R1165	-	SHORT 0	-	-	SHORT 0	SHORT 0	-	-	-	-	-	SHORT 0	-

S1 [STEREO PROCESSOR]

C [R, G, B OUT]

C Board

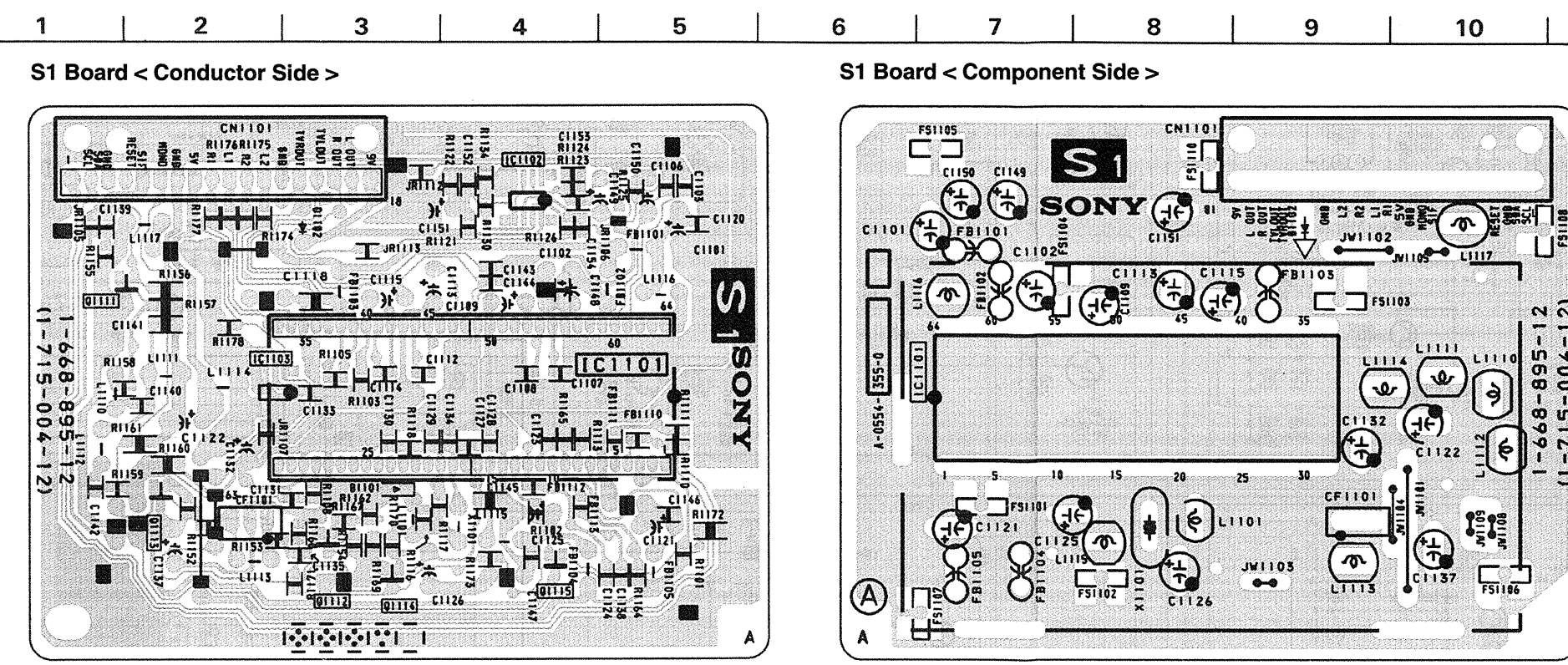
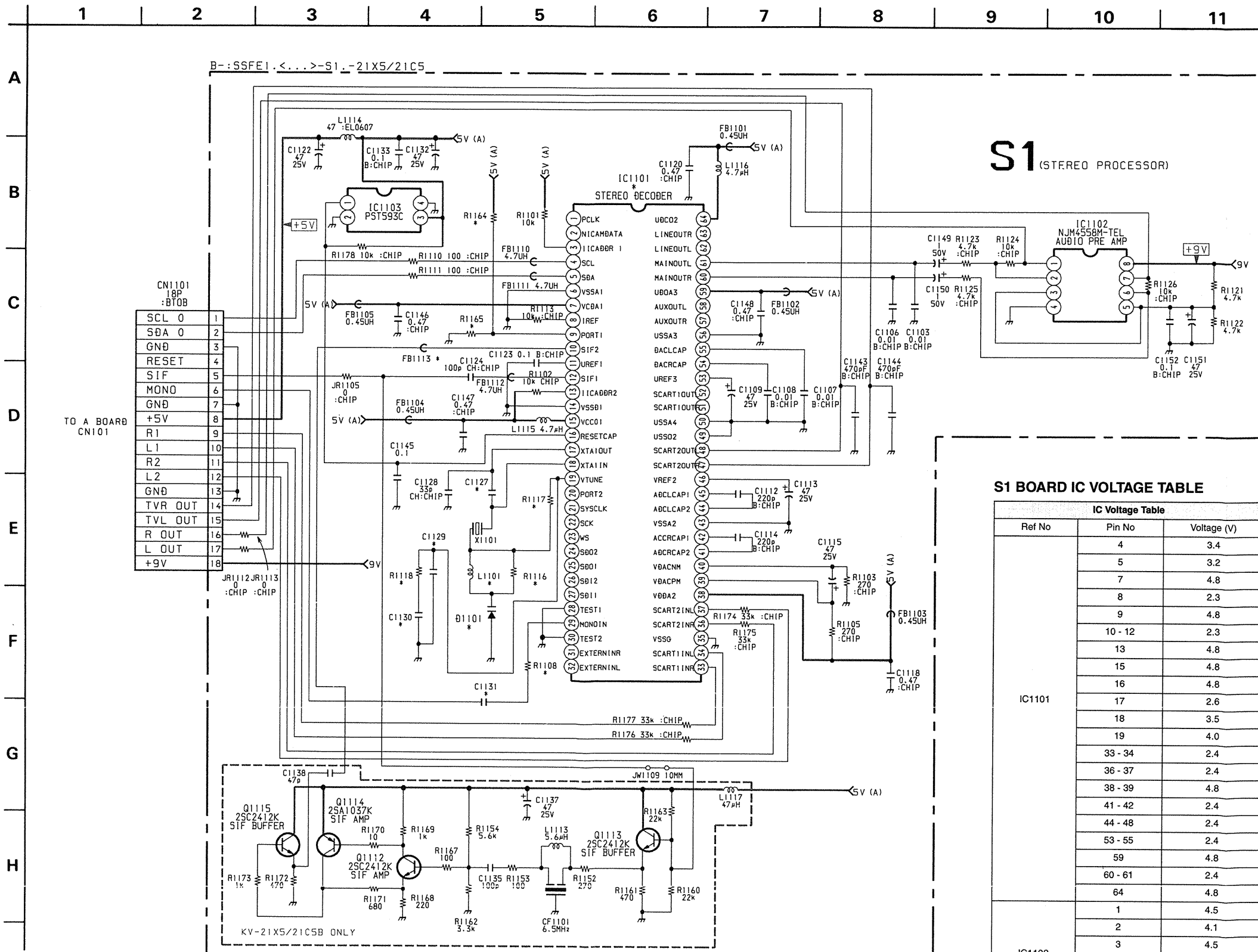
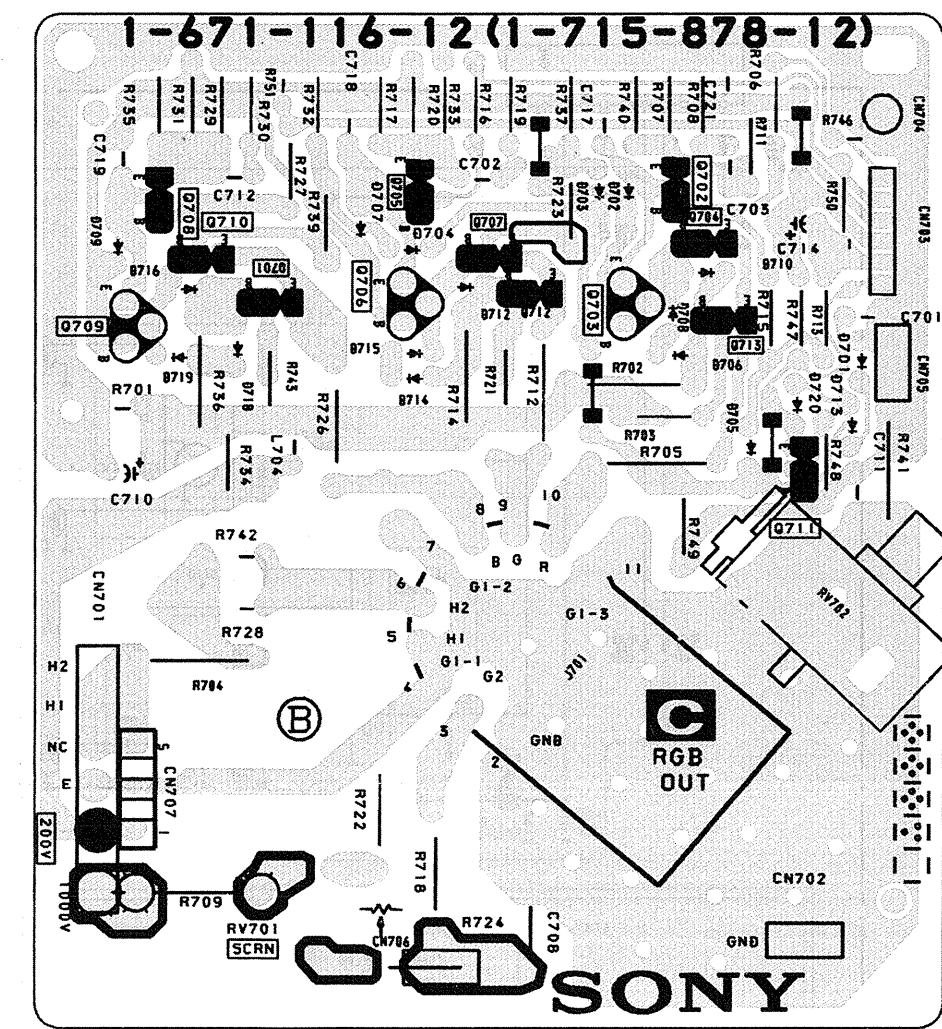

WAVEFORMS C BOARD

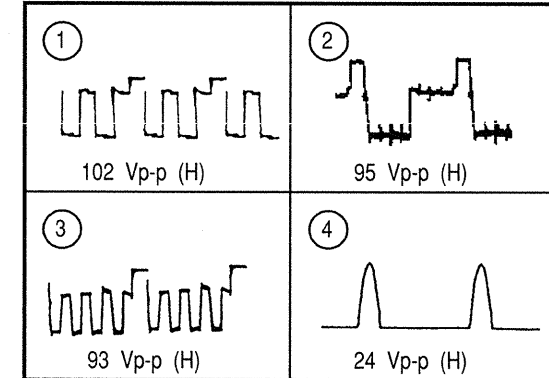

C BOARD TRANSISTOR VOLTAGE TABLE

Ref No	(B) Base	(C) Collector	(E) Emitter
Q702	1.5	8.3	1.1
Q703	0.8	169.8	8.3
Q704	169.5	1.9	209.5
Q705	1.5	8.3	1.1
Q706	8.8	170.7	8.3
Q707	170.5	1.9	215.7
Q708	1.5	8.3	1.0
Q709	8.9	171.3	8.3
Q710	171.2	1.9	206.3

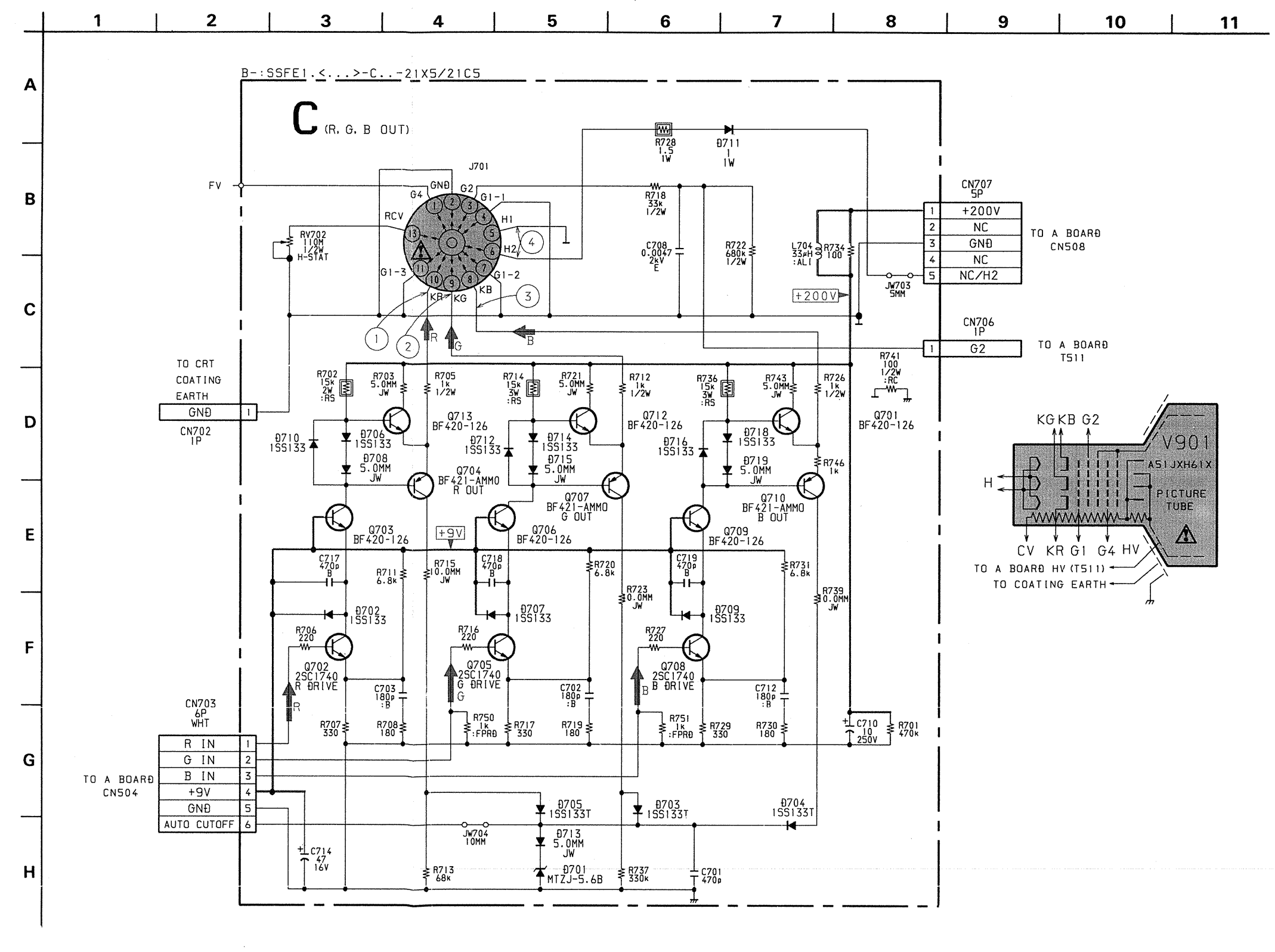

WAVEFORMS A BOARD

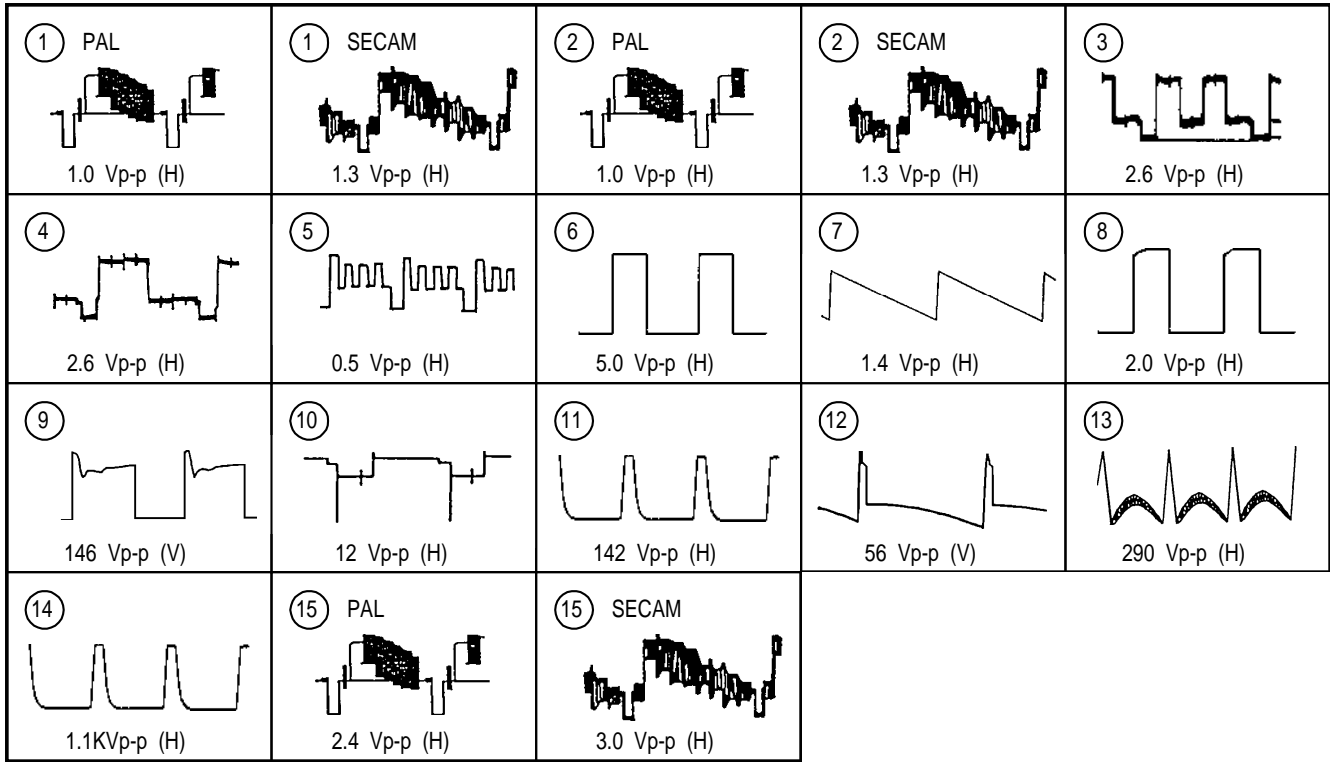

WAVEFORMS C BOARD

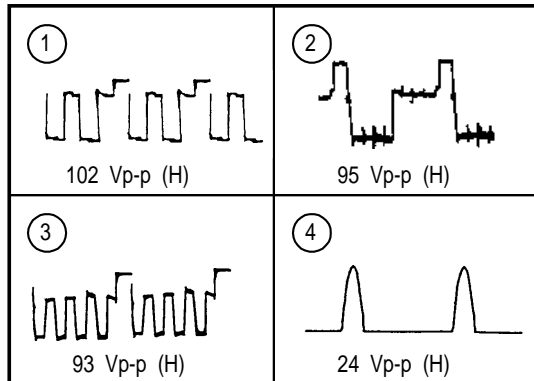

5-4 SEMICONDUCTORS

CD4052BCM

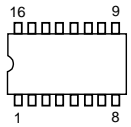

(TOP VIEW)

LM2940CT-9.0

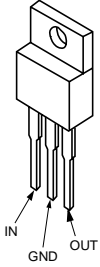

LM393N
TDA2822M
TEA2124

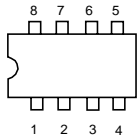

(TOP VIEW)

NJM4558M-TE2

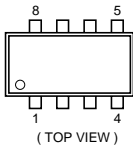

(TOP VIEW)

PST593C-MMP-4P

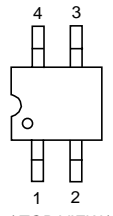

(TOP VIEW)

SAA5498PS/M1A/074
SAA5498PS/M1A/075
SAA5498PS/M1A/076

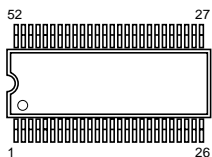

(TOP VIEW)

SBX1981-51

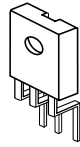

STR-F6654

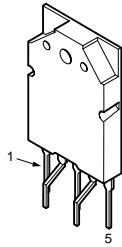

STV9379

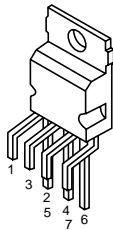

ST24W08FM6TR

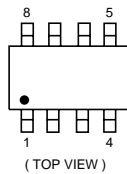

(TOP VIEW)

TDA7495

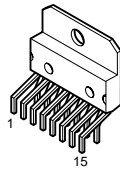

TDA9818-V1

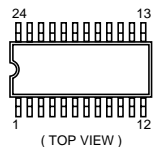

(TOP VIEW)

TDA9870
TDA9875P

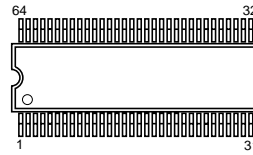

(TOP VIEW)

TOP209P

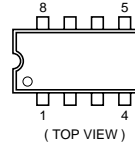

(TOP VIEW)

TYA7805CTV

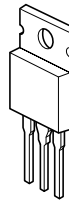

BF421-AMMO
2SA1091-O

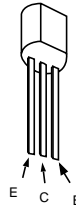

E C B

2SC688-LK

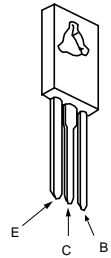

SD2539 (SONY)

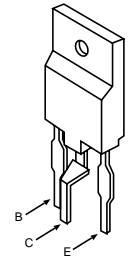

2SA933AS-QRT
2SA933AS-RT
2SC1740S-RT

LETTER SIDE

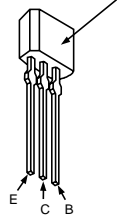

E C B

- | | |
|-------------|-----------------|
| AK04-V1 | GP08DPKG23 |
| AU-01Z-V1 | GP10GPKG23 |
| DINL20-TA | GP15GPKG23 |
| ERB44-06TP1 | LSB360HL |
| EG-1Z-V1 | RB501V-40TE-T7 |
| EL1Z | RG1CLF-B1 |
| ERD28-06S | RGPO2-17EL-6433 |
| ERC06-15S | RGP15GPKG23 |
| FMN-G12S | RGP10GPKG23 |
| | RU-4AM-T3 |

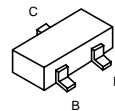

C B E

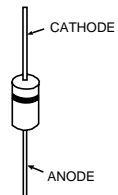

CATHODE

ANODE

5-4 SEMICONDUCTORS

DAN202K
DAN202K-T146

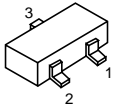

D45B60L-F

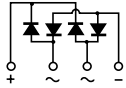
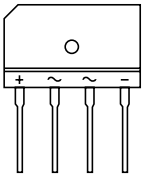

AK04WS	MTZJ-T-77-33A
ERC04-6SE	P6KE200AG23
MTZJ-T-77-4.7B	RD5.6ESB2
MTZJ-T-77-5.6B	RN3Z-LF014-302
MTZJ-T-77-12B	1SS119-25TD
MTZJ-T-77-22B	1SS133T-77

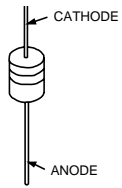

UF4005PKG23

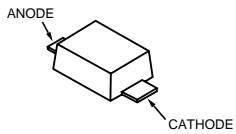

5-5. IC BLOCK DIAGRAMS

A BOARD IC501 STV 9379

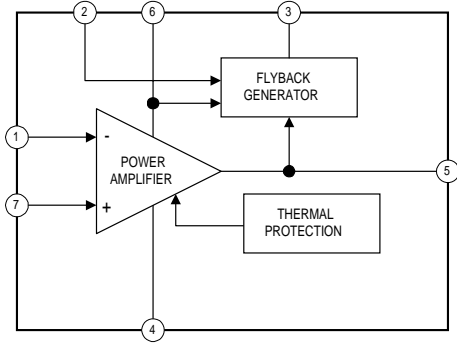

A BOARD IC201 TDA7495

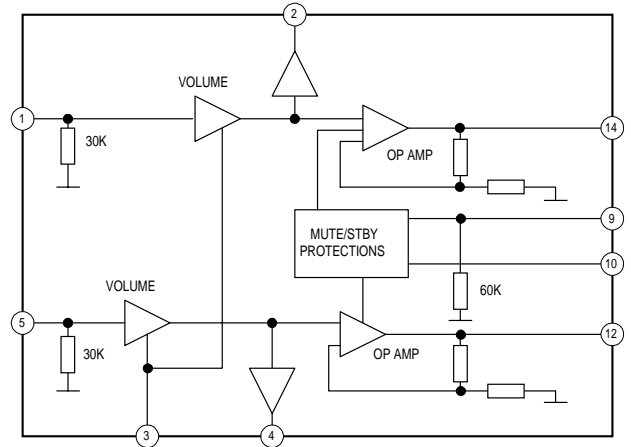

A BOARD IC101 TDA9817/V1

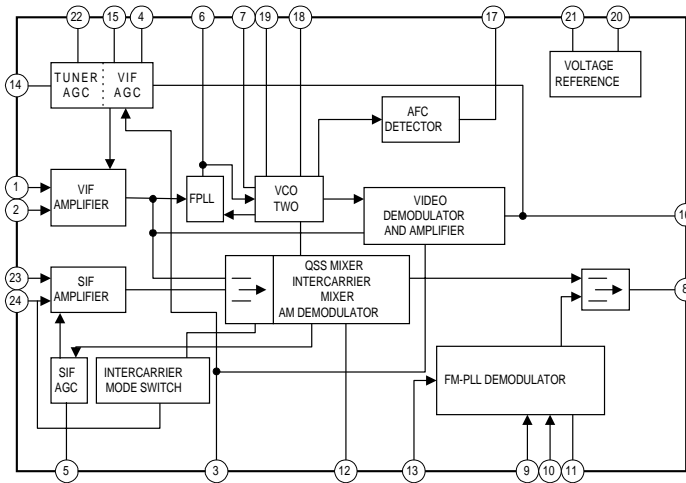

A BOARD IC606 STR-F6654

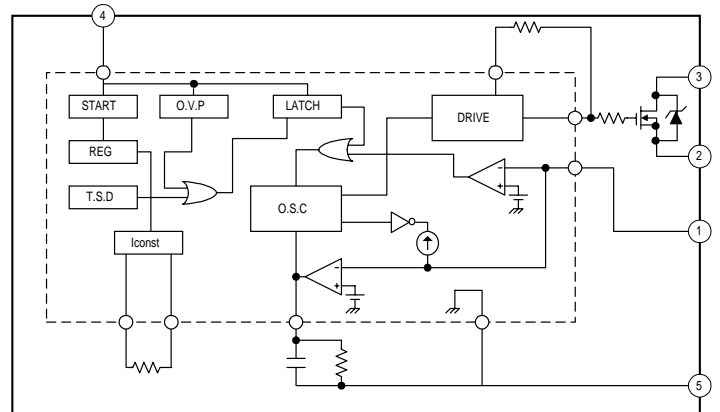

A BOARD IC301 CXA2060AS

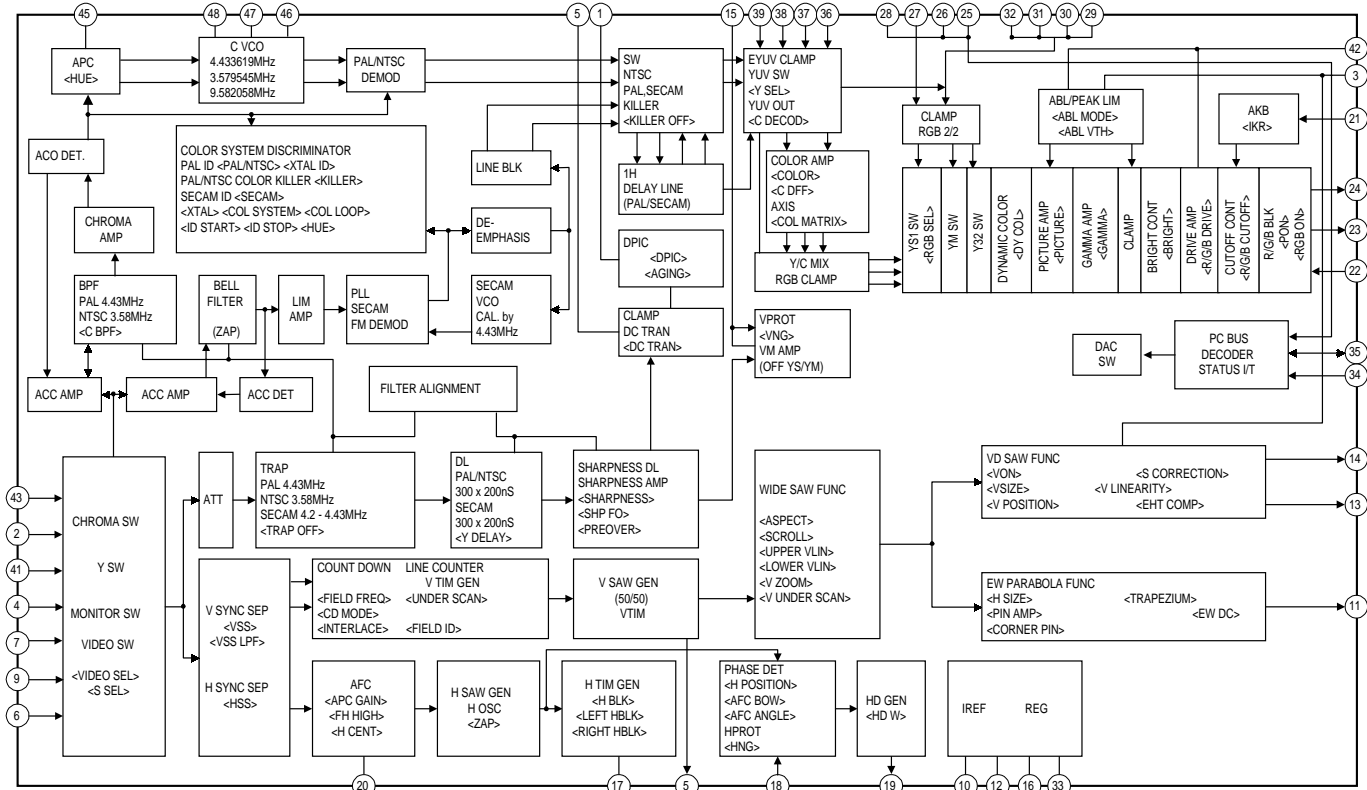

SECTION 6 EXPLODED VIEWS

NOTE :

- Items with no part number and no description are not stocked because they are seldom required for routine service.
- The construction parts of an assembled part are indicated with a collation number in the remarks column.

- Items marked “ * “ are not stocked since they are seldom required for routine service. Some delay should be anticipated when ordering these items.

Note : Les composants identifiés par une trame et par une marque Δ sont d'une importance critique pour la sécurité. Ne les remplacer que par des pièces du numéro spécifié.

Note : The components identified by shading and marked Δ are critical for safety. Replace only with the part numbers specified in the parts list.

6-1. KV-21C5 CHASSIS

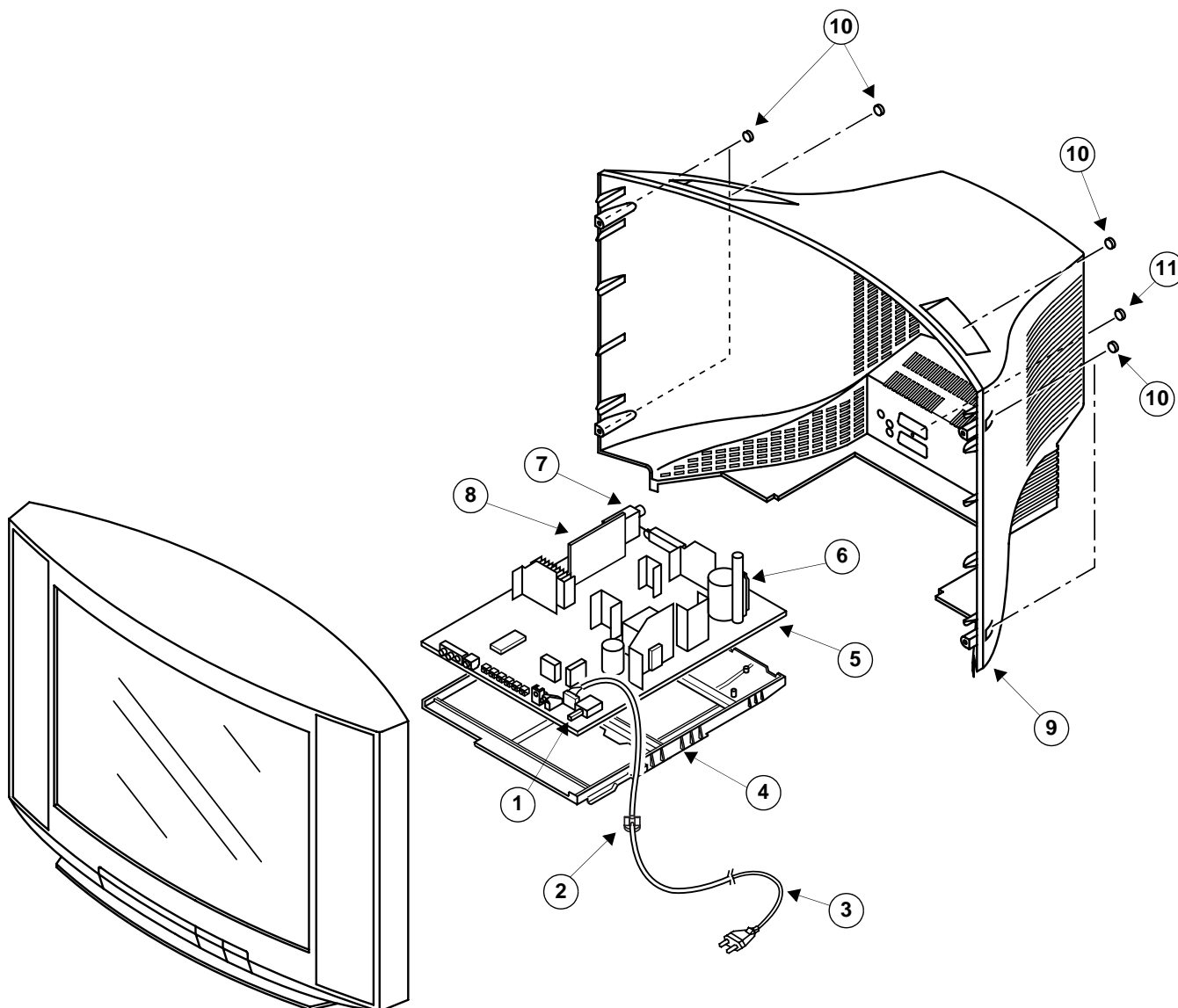

REF. NO.	PART. NO	DESCRIPTION	REMARK	REF. NO.	PART. NO	DESCRIPTION	REMARK
1	△ 1-571-433-21	SWITCH, PUSH (AC POWER)		7	1-693-418-11	TUNER (TELE9-001A) (KV-21C5B)	
2	*4-202-531-01	AC CORD LOCK (SC)			8-598-432-00	TUNER (BTP-AC411) (KV-21C5D/21C5E/21C5K/21C5R)	
3	△ 1-765-286-11	CORD, POWER		8	*A-1652-056-A	S1 BOARD, COMPLETE (KV-21C5B)	
4	*4-204-143-01	BRACKET, MAIN			*A-1652-053-A	S1 BOARD, COMPLETE (KV-21C5D/21C5R)	
5	*A-1632-798-A	A BOARD, COMPLETE (KV-21C5B)			*A-1652-052-A	S1 BOARD, COMPLETE (KV-21C5E/21C5K)	
	*A-1632-797-A	A BOARD, COMPLETE (KV-21C5D)		9	4-204-147-01	COVER, REAR	
	*A-1632-796-A	A BOARD, COMPLETE (KV-21C5E)		10	7-685-663-71	SCREW +BVTP 4X16 TYPE2 IT-3	
	*A-1632-799-A	A BOARD, COMPLETE (KV-21C5K)		11	7-685-663-79	SCREW +BVTP 4X16 TYPE2 IT-3	
	*A-1632-800-A	A BOARD, COMPLETE (KV-21C5R)					
6	△ 1-453-279-11	TRANSFORMER ASSY, FLYBACK NX-1747/U2B					

6-2. KV-21C5 PICTURE TUBE

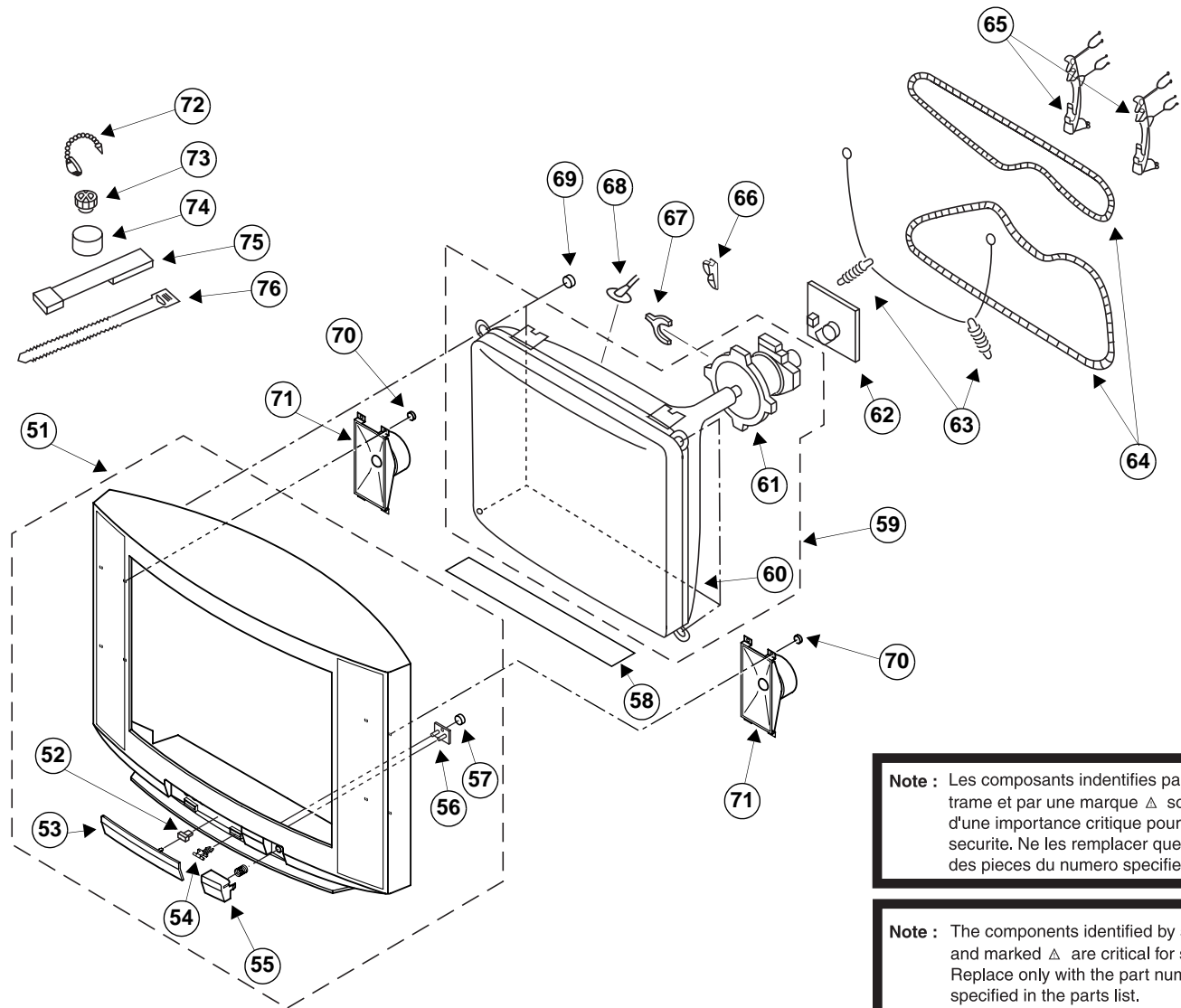

Note : Les composants identifiés par une trame et par une marque Δ sont d'une importance critique pour la sécurité. Ne les remplacer que par des pièces du numéro spécifié.

Note : The components identified by shading and marked Δ are critical for safety. Replace only with the part numbers specified in the parts list.

REF. NO.	PART.NO	DESCRIPTION	REMARK	REF. NO.	PART.NO	DESCRIPTION	REMARK
51	X-4200-410-1	BEZNET ASSY (KV-21C5B/21C5E/21C5K)	52-57	63	4-369-318-21	SPRING, TENSION	
	X-4200-411-1	BEZNET ASSY (KV-21C5D/21C5R)		64	Δ 1-411-922-11	COIL, DEGAUSSING	
52	4-047-464-01	CATCHER, PUSH		65	4-386-622-11	BAND, DGC	
53	4-204-359-01	DOOR (PAINTED) (KV-21C5B/21C5E/21C5K)		66	3-704-495-01	SPACER, DY	
	4-204-359-11	DOOR (PAINTED) (KV-21C5D/21C5R)		67	1-452-277-00	MAGNET, BMC	
54	3-703-035-11	SHAFT, LID		68	Δ 1-540-006-22	CAP ASSY, HIGH-VOLTAGE	
55	4-204-360-01	BUTTON, POWER		69	4-365-808-01	SCREW (5), TAPPING	
56	4-204-146-01	GUIDE, LIGHT		70	7-685-663-71	SCREW +BVTP 4X16 TYPE2 IT-3	
57	7-685-648-79	SCREW +BVTP 3X16 TYPE2 IT-3		71	1-505-924-11	SPEAKER (15X6.5CM)	
58	4-203-128-01	SHEET BLOTING		72	4-308-870-00	CLIP, LEAD WIRE	
59	Δ 8-738-787-71	ITC	60-61	73	1-452-032-00	MAGNETIC, ROTATABLE DISK; 15MM \emptyset	
60	Δ 8-738-784-05	PICTURE TUBE (SD-169) (A51JXH161X)		74	1-452-094-00	MAGNETIC, DISK; 10MM \emptyset	
61	Δ 8-451-295-45	DEFLECTION YOKE (Y21PFA2BA)		75	X-4387-214-1	PERMALLOY ASSY, CORRECTION	
62	*A-1638-118-A	C BOARD, COMPLETE		76	3-701-007-00	BAND, BINDING	

6-3. KV-21X5 CHASSIS

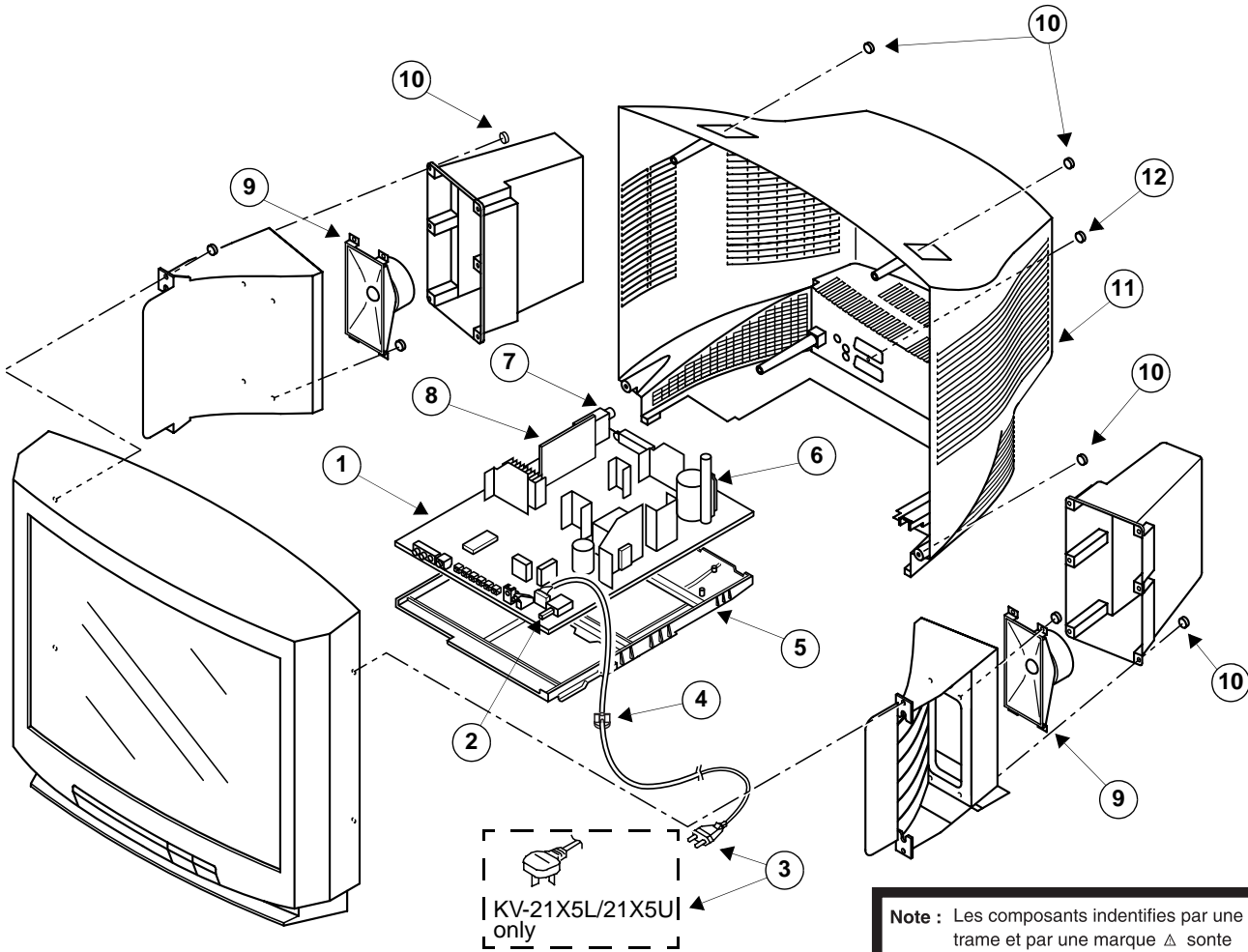

Note : Les composants identifiés par une trame et par une marque Δ sont d'une importance critique pour la securite. Ne les remplacer que par des pieces du numero specifie.

Note : The components identified by shading and marked Δ are critical for safety. Replace only with the part numbers specified in the parts list.

REF. NO.	PART.NO	DESCRIPTION	REMARK	REF. NO.	PART.NO	DESCRIPTION	REMARK
1	*A-1632-804-A	A BOARD, COMPLETE (KV-21X5A)		7	1-693-418-11	TUNER (TELE9-001A) (KV-21X5B)	
	*A-1632-803-A	A BOARD, COMPLETE (KV-21X5B)			8-598-432-00	TUNER (BTP-AC411) (KV-21X5A/21X5D/21X5E/21X5K/21X5L/21X5R)	
	*A-1632-802-A	A BOARD, COMPLETE (KV-21X5D)			8-598-464-01	TUNER (BTP-AU611) (KV-21X5U)	
	*A-1632-801-A	A BOARD, COMPLETE (KV-21X5E)		8	*A-1652-053-A	S1 BOARD, COMPLETE (KV-21X5A/21X5D/21X5R)	
	*A-1632-807-A	A BOARD, COMPLETE (KV-21X5K)			*A-1652-056-A	S1 BOARD, COMPLETE (KV-21X5B)	
	*A-1632-806-A	A BOARD, COMPLETE (KV-21X5L)			*A-1652-052-A	S1 BOARD, COMPLETE (KV-21X5E/21X5K/21X5L/21X5U)	
	*A-1632-808-A	A BOARD, COMPLETE (KV-21X5R)		9	4-505-924-01	SPEAKER (15X6.5CM)	
	*A-1632-805-A	A BOARD, COMPLETE (KV-21X5U)		10	7-685-663-71	SCREW +BVTP 4X16 TYPE2 IT-3	
2	Δ 1-571-433-21	SWITCH, PUSH (AC POWER)		11	4-204-167-01	COVER, REAR	
3	Δ 1-765-286-11	CORD, POWER		12	7-685-663-79	SCREW +BVTP 4X16 TYPE2 IT-3	
4	*4-202-531-01	AC CORD LOCK (SC)					
5	*4-204-143-01	BRACKET, MAIN					
6	Δ 1-453-279-11	TRANSFORMER ASSY, FLYBACK NX-1747/U2B					

6-4. KV-21X5 PICTURE TUBE

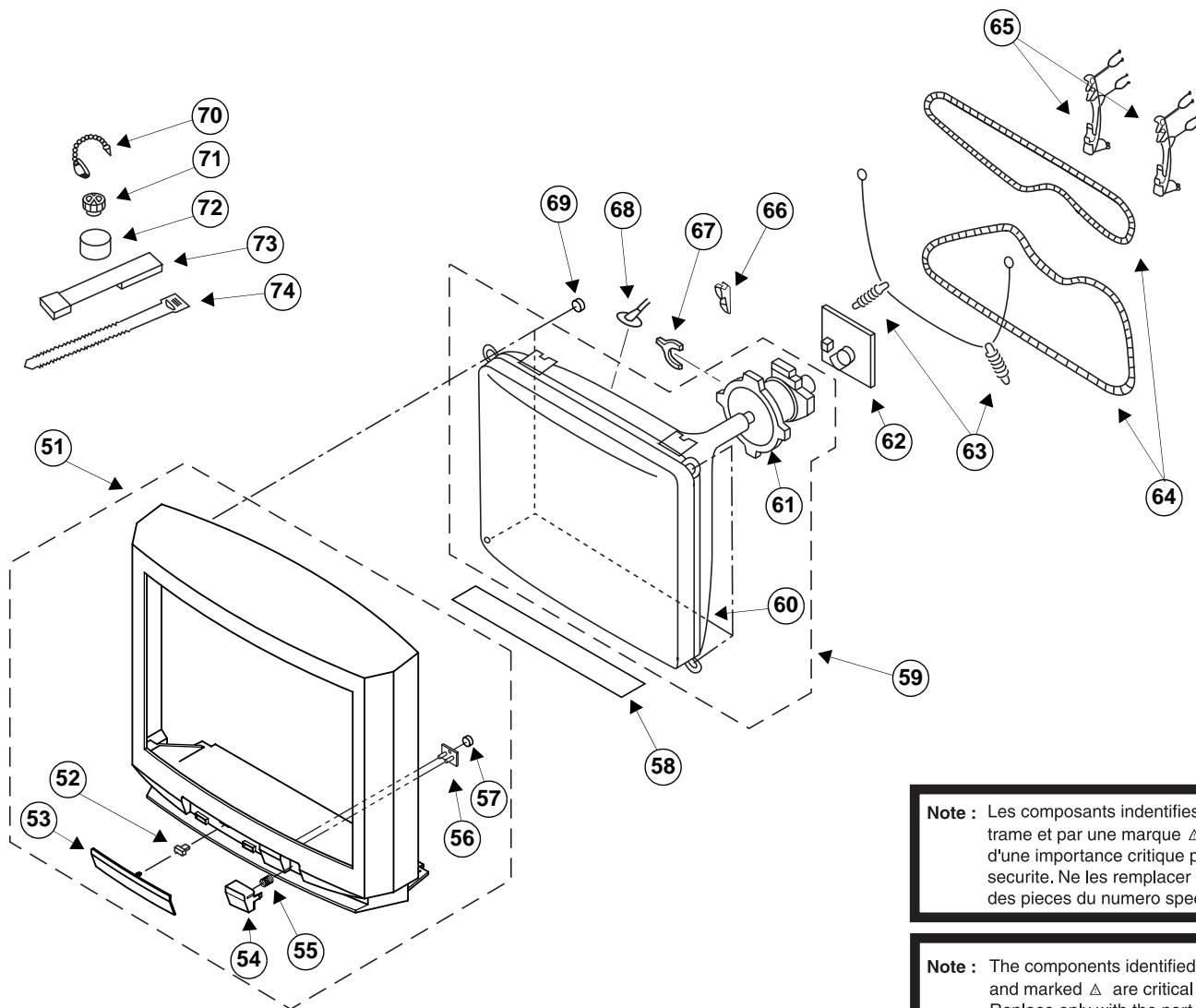

Note : Les composants indentifiés par une trame et par une marque Δ sont d'une importance critique pour la sécurité. Ne les remplacer que par des pièces du numéro spécifié.

Note : The components identified by shading and marked Δ are critical for safety. Replace only with the part numbers specified in the parts list.

REF. NO.	PART.NO	DESCRIPTION	REMARK	REF. NO.	PART.NO	DESCRIPTION	REMARK
51	X-4200-402-2	BEZNET ASSY (KV-21X5A/21X5D/21X5R)	52-57	62	*A-1638-118-A	C BOARD, COMPLETE	
	X-4200-402-1	BEZNET ASSY (KV-21X5B/21X5E/21X5K/21X5L/21X5U)		63	4-369-318-21	SPRING, TENSION	
52	4-047-464-01	CATCHER, PUSH		64	Δ 1-411-922-11	COIL, DEGAUSSING	
53	4-204-170-11	DOOR (KV-21X5A/21X5D/21X5R)		65	4-386-622-11	BAND, DGC	
	4-204-170-01	DOOR (KV-21X5B/21X5E/21X5K/21X5L/21X5U)		66	3-704-495-01	SPACER, DY	
54	4-204-171-01	BUTTON, POWER		67	1-452-277-00	MAGNET, BMC	
55	3-202-964-01	SPRING		68	Δ 1-540-006-22	CAP ASSY, HIGH-VOLTAGE	
56	4-204-172-01	GUIDE, LIGHT		69	4-365-808-01	SCREW (5), TAPPING	
57	7-685-648-79	SCREW +BVTP 3X16 TYPE2 IT-3		70	4-308-870-00	CLIP, LEAD WIRE	
58	4-203-128-01	SHEET BLOTTING		71	1-452-094-00	MAGNETIC, ROTATABLE DISK; 15MM \emptyset	
59	Δ 8-738-787-71	ITC	60-61	72	1-452-032-00	MAGNETIC, DISK; 10MM \emptyset	
60	Δ 8-738-784-05	PICTURE TUBE (SD-169) (A51JXH61X)		73	X-4387-214-1	PERMALLOY ASSY, CORRECTION	
61	Δ 8-451-295-45	DEFLECTION YOKE (Y21PFA2BA)		74	3-701-007-00	BAND, BINDING	

SECTION 7 ELECTRICAL PARTS LIST

When indicating parts by reference number, please include the board name.

CAPACITORS COILS
MF : mF, PF : mmF MMH : mH , uH

- Items marked “ * “ are not stocked since they are seldom required for routine service. Some delay should be anticipated when ordering these items.
- All variable and adjustable resistors have characteristic curve B, unless otherwise noted.
- RESISTORS
- All resistors are in ohms.
- F : nonflammable.

Note : Les composants identifiés par une trame et par une marque Δ sont d'une importance critique pour la sécurité. Ne les remplacer que par des pièces du numéro spécifié.

Note : The components identified by shading and marked Δ are critical for safety. Replace only with the part numbers specified in the parts list.

A

REF.NO.	PART.NO	DESCRIPTION	REMARK	REF.NO.	PART.NO	DESCRIPTION	REMARK
*A-1632-798-A		A BOARD, COMPLETE *****	(KV-21C5B)	C018	1-164-232-11	CERAMIC CHIP 0.01MF	10% 50V
*A-1632-797-A		A BOARD, COMPLETE *****	(KV-21C5D)	C019	1-163-038-00	CERAMIC CHIP 0.1MF	25V
*A-1632-796-A		A BOARD, COMPLETE *****	(KV-21C5E)	C022	1-126-935-11	ELECT 470MF	20% 16V
*A-1632-799-A		A BOARD, COMPLETE *****	(KV-21C5K)	C024	1-104-665-11	ELECT 100MF	20% 25V
*A-1632-800-A		A BOARD, COMPLETE *****	(KV-21C5R)	C025	1-130-495-00	FILM 0.1MF	5% 50V
*A-1632-804-A		A BOARD, COMPLETE *****	(KV-21X5A)	C029	1-163-077-00	CERAMIC CHIP 0.1MF	10% 25V
*A-1632-803-A		A BOARD, COMPLETE *****	(KV-21X5B)	C030	1-104-665-11	ELECT 100MF	20% 25V
*A-1632-802-A		A BOARD, COMPLETE *****	(KV-21X5D)	C031	1-163-017-00	CERAMIC CHIP 0.0047MF	10% 50V
*A-1632-801-A		A BOARD, COMPLETE *****	(KV-21X5E)	C032	1-163-077-00	CERAMIC CHIP 0.1MF	10% 25V
*A-1632-807-A		A BOARD, COMPLETE *****	(KV-21X5K)	C033	1-164-004-11	CERAMIC CHIP 0.1MF	10% 25V
*A-1632-806-A		A BOARD, COMPLETE *****	(KV-21X5L)	C035	1-164-232-11	CERAMIC CHIP 0.01MF	10% 50V
*A-1632-808-A		A BOARD, COMPLETE *****	(KV-21X5R)	C036	1-163-017-00	CERAMIC CHIP 0.0047MF	10% 50V
*A-1632-805-A		A BOARD, COMPLETE *****	(KV-21X5U)	C037	1-163-017-00	CERAMIC CHIP 0.0047MF	10% 50V
4-382-854-11		SCREW (M3X10), P, SW (+)		C038	1-126-964-11	ELECT 10MF	20% 50V
		< CAPACITOR >		C039	1-163-017-00	CERAMIC CHIP 0.0047MF	10% 50V
C004	1-163-038-00	CERAMIC CHIP 0.1MF	25V	C040	1-163-189-00	CERAMIC CHIP 220PF	5% 50V
C005	1-163-105-00	CERAMIC CHIP 33PF	5% 50V	C041	1-163-205-00	CERAMIC CHIP 0.001MF	10% 50V
C006	1-163-105-00	CERAMIC CHIP 33PF	5% 50V	C042	1-126-933-11	ELECT 100MF	20% 16V
C007	1-126-935-11	ELECT 470MF	20% 16V	C043	1-126-935-11	ELECT 470MF	20% 16V
C008	1-126-964-11	ELECT 10MF	20% 50V	C100	1-163-038-00	CERAMIC CHIP 0.1MF	25V (KV-21C5B/21X5B)
C009	1-126-965-11	ELECT 22MF	20% 50V	C103	1-104-665-11	ELECT 100MF	20% 25V
C011	1-126-965-11	ELECT 22MF	20% 50V	C105	1-126-965-11	ELECT 22MF	20% 50V
C012	1-126-959-11	ELECT 0.47MF	20% 50V	C108	1-163-465-11	CERAMIC CHIP 9PF	0.25PF 50V
C013	1-163-017-00	CERAMIC CHIP 0.0047MF	10% 50V	C109	1-164-004-11	CERAMIC CHIP 0.1MF	10% 25V
C016	1-164-004-11	CERAMIC CHIP 0.1MF	10% 25V	C110	1-163-038-00	CERAMIC CHIP 0.1MF	25V
				C111	1-163-059-00	CERAMIC CHIP 0.01MF	50V (KV-21C5B/21X5B)
					1-216-296-00	SHORT 0	(KV-21C5D/21C5E/21C5K/21C5R) (KV-21X5A/21X5D/21X5E/21X5K/ 21X5L/21X5R/21X5U)
				C112	1-163-031-11	CERAMIC CHIP 0.01MF	50V
				C115	1-164-489-11	CERAMIC CHIP 0.22MF	10% 16V
				C116	1-126-961-11	ELECT 2.2MF	20% 50V
				C117	1-126-961-11	ELECT 2.2MF	20% 50V



REF. NO.	PART.NO	DESCRIPTION	REMARK	REF. NO.	PART.NO	DESCRIPTION	REMARK
C118	1-163-038-00	CERAMIC CHIP 0.1MF	25V	C319	1-126-964-11	ELECT 10MF	20% 50V
C120	1-163-031-11	CERAMIC CHIP 0.01MF	50V	C321	1-126-963-11	ELECT 4.7MF	20% 50V
C121	1-163-031-11	CERAMIC CHIP 0.01MF	50V	C322	1-164-004-11	CERAMIC CHIP 0.1MF	10% 25V
			(KV-21C5B/21X5B)	C328	1-104-664-11	ELECT 47MF	20% 25V
C129	1-104-660-91	ELECT 47MF	20% 16V	C329	1-164-232-11	CERAMIC CHIP 0.01MF	10% 50V
				C330	1-163-038-00	CERAMIC CHIP 0.1MF	25V
C133	1-162-638-11	CERAMIC CHIP 1MF	16V	C331	1-164-232-11	CERAMIC CHIP 0.01MF	10% 50V
			(KV-21C5B/21X5B)	C332	1-164-232-11	CERAMIC CHIP 0.01MF	10% 50V
C134	1-128-551-11	ELECT 22MF	20% 25V	C333	1-126-960-11	ELECT 1MF	20% 50V
C135	1-164-004-11	CERAMIC CHIP 0.1MF	10% 25V	C334	1-163-017-00	CERAMIC CHIP 0.0047MF	10% 50V
C138	1-165-319-11	CERAMIC CHIP 0.1MF	50V				
				C335	1-164-232-11	CERAMIC CHIP 0.01MF	10% 50V
C139	1-163-031-11	CERAMIC CHIP 0.01MF	50V	C336	1-164-232-11	CERAMIC CHIP 0.01MF	10% 50V
C140	1-163-031-11	CERAMIC CHIP 0.01MF	50V	C337	1-164-232-11	CERAMIC CHIP 0.01MF	10% 50V
C143	1-104-664-11	ELECT 47MF	20% 25V	C338	1-126-967-11	ELECT 47MF	20% 50V
C144	1-163-017-00	CERAMIC CHIP 0.0047MF	10% 50V	C339	1-163-038-00	CERAMIC CHIP 0.1MF	25V
			(KV-21C5B/21X5B)				
C146	1-163-031-11	CERAMIC CHIP 0.01MF	50V	C350	1-163-017-00	CERAMIC CHIP 0.0047MF	10% 50V
C160	1-163-017-00	CERAMIC CHIP 0.0047MF	10% 50V	C351	1-163-017-00	CERAMIC CHIP 0.0047MF	10% 50V
C201	1-104-666-11	ELECT 220MF	20% 25V	C401	1-163-141-00	CERAMIC CHIP 0.001MF	5% 50V
C203	1-126-942-61	ELECT 1000MF	20% 25V	C402	1-126-960-11	ELECT 1MF	20% 50V
C204	1-126-942-61	ELECT 1000MF	20% 25V	C403	1-163-017-00	CERAMIC CHIP 0.0047MF	10% 50V
				C405	1-163-141-00	CERAMIC CHIP 0.001MF	5% 50V
C205	1-163-033-91	CERAMIC CHIP 0.022MF	50V	C406	1-126-960-11	ELECT 1MF	20% 50V
C206	1-126-960-11	ELECT 1MF	20% 50V	C407	1-126-964-11	ELECT 10MF	20% 50V
C207	1-126-972-11	ELECT 1000MF	20% 50V	C408	1-126-964-11	ELECT 10MF	20% 50V
C208	1-126-960-11	ELECT 1MF	20% 50V	C410	1-126-964-11	ELECT 10MF	20% 50V
C209	1-163-033-91	CERAMIC CHIP 0.022MF	50V				
				C413	1-163-141-00	CERAMIC CHIP 0.001MF	5% 50V
C210	1-163-009-11	CERAMIC CHIP 0.001MF	10% 50V	C414	1-126-960-11	ELECT 1MF	20% 50V
C211	1-163-009-11	CERAMIC CHIP 0.001MF	10% 50V	C415	1-163-017-00	CERAMIC CHIP 0.0047MF	10% 50V
C213	1-163-019-00	CERAMIC CHIP 0.0068MF	10% 50V	C416	1-126-964-11	ELECT 10MF	20% 50V
C214	1-163-019-00	CERAMIC CHIP 0.0068MF	10% 50V	C417	1-163-141-00	CERAMIC CHIP 0.001MF	5% 50V
C215	1-164-004-11	CERAMIC CHIP 0.1MF	10% 25V				
				C418	1-126-960-11	ELECT 1MF	20% 50V
C218	1-102-074-00	CERAMIC CHIP 0.001MF	5% 50V	C422	1-163-017-00	CERAMIC CHIP 0.0047MF	10% 50V
			(KV-21C5B/21X5B)	C423	1-126-964-11	ELECT 10MF	20% 50V
C219	1-102-074-00	CERAMIC 0.001MF	10% 50V	C426	1-163-009-11	CERAMIC CHIP 0.001MF	10% 50V
			(KV-21C5B/21X5B)	C427	1-535-303-00	LEAD, JUMPER (5.0MM)	
C301	1-163-038-00	CERAMIC CHIP 0.1MF	25V				
				C428	1-163-009-11	CERAMIC CHIP 0.001MF	10% 50V
C302	1-126-967-11	ELECT 47MF	20% 16V	C429	1-535-303-00	LEAD, JUMPER (5.0MM)	
C303	1-101-004-00	CERAMIC 0.01MF	50V	C430	1-104-664-11	ELECT 47MF	20% 25V
C304	1-126-964-11	ELECT 10MF	20% 50V	C432	1-163-141-00	CERAMIC CHIP 0.001MF	5% 50V
C305	1-163-005-11	CERAMIC CHIP 470PF	10% 50V	C433	1-163-141-00	CERAMIC CHIP 0.001MF	5% 50V
C307	1-164-232-11	CERAMIC CHIP 0.01MF	10% 50V				
				C434	1-126-935-11	ELECT 470MF	20% 16V
C308	1-164-004-11	CERAMIC CHIP 0.1MF	10% 25V	C435	1-163-017-00	CERAMIC CHIP 0.0047MF	10% 50V
C309	1-126-963-11	ELECT 4.7MF	20% 50V	C436	1-163-055-00	CERAMIC CHIP 0.0047MF	10% 50V
C312	1-163-099-00	CERAMIC CHIP 18PF	5% 50V	C437	1-124-903-11	ELECT 1MF	20% 50V
C313	1-163-099-00	CERAMIC CHIP 18PF	5% 50V	C438	1-124-903-11	ELECT 1MF	20% 50V
C314	1-163-038-00	CERAMIC CHIP 0.1MF	25V				
				C443	1-163-017-00	CERAMIC CHIP 0.0047MF	10% 50V
C316	1-163-259-91	CERAMIC CHIP 220PF	5% 50V	C444	1-163-017-00	CERAMIC CHIP 0.0047MF	10% 50V
C317	1-136-169-00	FILM 0.22MF	5% 50V				

A

The components identified by shading and marked Δ are critical for safety
 Replace only with the part number specified.

REF. NO.	PART.NO	DESCRIPTION	REMARK	REF. NO.	PART.NO	DESCRIPTION	REMARK
C445	1-163-017-00	CERAMIC CHIP 0.0047MF	10% 50V	C606	1-125-318-00	ELECT (BLOCK) 220MF	20% 400V (KV-21C5B/21C5D/21C5E)
C501	1-126-968-11	ELECT 100MF	20% 50V				(KV-21X5A/21X5B/21X5D/ 21X5E/21X5L/21X5U)
C502	1-163-038-00	CERAMIC CHIP 0.1MF	25V				
C503	1-126-968-11	ELECT 100MF	20% 50V				
C504	1-106-220-00	MYLAR 0.1MF	10% 100V	1-117-751-11	ELECT (BLOCK) 220MF	20% 450V (KV-21C5K/21C5R) (KV-21X5K/21X5R)	
C505	1-136-173-00	FILM 0.47MF	5% 50V				
C506	1-164-232-11	CERAMIC CHIP 0.01MF	10% 50V	C607	1-161-754-00	CERAMIC 0.001MF	10% 2KV
C507	1-126-933-11	ELECT 100MF	20% 16V	C609	1-107-915-51	ELECT 2200MF	20% 50V
C508	1-126-960-11	ELECT 1MF	20% 50V	C610	1-104-665-11	ELECT 100MF	20% 25V
C509	1-107-364-11	MYLAR 0.01MF	10% 200V	C611	1-165-127-11	CERAMIC 470PF	10% 500V
C510	1-163-005-11	CERAMIC CHIP 470PF	10% 50V	C612 Δ	1-161-964-51	CERAMIC 0.0047MF	250V
C513	1-107-662-11	ELECT 22MF	20% 250V				
C515	1-104-666-11	ELECT 220MF	20% 25V	C613 Δ	1-161-964-51	CERAMIC 0.0047MF	250V
C517	1-104-666-11	ELECT 220MF	20% 25V	C614 Δ	1-161-964-51	CERAMIC 0.0047MF	250V
C518	1-106-375-12	MYLAR 0.022MF	99% 200V	C615	1-130-202-00	FILM 0.022MF	10% 400V
C519	1-163-275-11	CERAMIC CHIP 0.001MF	5% 50V	C618	1-107-890-11	ELECT 2200MF	20% 25V
C520	1-163-038-00	CERAMIC CHIP 0.1MF	25V	C621	1-163-005-11	CERAMIC CHIP 470PF	10% 50V
C531	1-126-964-11	ELECT 10MF	20% 50V				
C535	1-163-251-11	CERAMIC CHIP 100PF	5% 50V	C622 Δ	1-161-964-51	CERAMIC 0.0047MF	250V
C536	1-107-804-11	FILM 0.68MF	5% 200V	C624	1-104-665-11	ELECT 100MF	20% 25V
C537	1-137-417-11	MYLAR 0.0047MF	10% 200V	C625	1-104-665-11	ELECT 100MF	20% 25V
C538	1-165-319-11	CERAMIC CHIP 0.1MF	50V	C628	1-124-347-00	ELECT 100MF	20% 160V
C539	1-107-650-11	ELECT 3.3MF	20% 250V	C629	1-136-189-00	FILM 0.1MF	10% 250V
C541	1-106-383-00	MYLAR 0.047MF	10% 200V				
C542	1-162-116-00	CERAMIC 680PF	10% 2KV	C630	1-165-127-11	CERAMIC 470PF	10% 500V
C543	1-162-134-11	CERAMIC 470PF	10% 2KV	C633	1-104-332-11	CERAMIC 470PF	10% 2KV
C545	1-126-960-11	ELECT 1MF	20% 50V	C635	1-107-675-11	ELECT 1MF	20% 160V
C546	1-129-746-00	FILM 0.039MF	5% 400V	C638	1-107-670-11	ELECT 10MF	20% 400V (KV-21C5B/21C5D/21C5E/21C5K) (KV-21X5A/21X5B/21X5D/21X5E/ 21X5K/21X5L/21X5U)
C547	1-115-522-11	FILM 1MF	5% 200V				
C548	1-162-134-11	CERAMIC 470PF	10% 2KV	1-107-679-91	ELECT 10MF	20% 450V (KV-21C5R/21X5R)	
C550	1-107-638-11	ELECT 33MF	20% 160V				
C552	1-102-212-00	CERAMIC 820PF	10% 500V	C639	1-104-665-11	ELECT 100MF	20% 25V
C553	1-137-417-11	MYLAR 0.0047MF	10% 200V	C640	1-104-664-11	ELECT 47MF	20% 25V
C555	1-117-644-11	FILM 10000PF	3% 1.2KV	C641	1-104-665-11	ELECT 100MF	20% 25V
C571	1-123-024-21	ELECT 33MF	160V	C642	1-104-665-11	ELECT 100MF	20% 25V
C572	1-128-526-11	ELECT 100MF	20% 25V				
C580	1-164-232-11	CERAMIC CHIP 0.01MF	10% 50V				
C582	1-163-017-00	CERAMIC CHIP 0.0047MF	10% 50V	CF101	1-404-134-00	TRAP, CERAMIC (5.5MHZ)	
C584	1-126-963-11	ELECT 4.7MF	20% 50V	CF105	1-760-154-11	TRAP, CERAMIC (KV-21C5B/21X5B/21X5L/21X5U)	
C601 Δ	1-107-563-11	FILM 0.1MF	20% 300V	SWF101	1-579-273-11	FILTER, SURFACE WAVE (KV-21C5B/21X5B/21X5L/21X5U)	
C602 Δ	1-107-563-11	FILM 0.1MF	20% 300V				
C603 Δ	1-117-700-51	CERAMIC 0.0022MF	99% 250V	1-767-874-11	FILTER, SURFACE WAVE (KV-21C5D/21C5E/21C5K/21C5R)		
C604 Δ	1-117-700-51	CERAMIC 0.0022MF	99% 250V				(KV-21X5A/21X5D/21X5E/21X5K/ 21X5R)
C605	1-104-652-11	ELECT 470MF	20% 10V				
				SWF102	1-767-873-11	FILTER, SURFACE WAVE	
				SWF103	1-767-083-11	FILTER, SURFACE WAVE (KV-21C5B/21X5B)	

< FILTER >

The components identified by shading and marked Δ are critical for safety
 Replace only with the part number specified.

A

REF. NO.	PART.NO	DESCRIPTION	REMARK	REF. NO.	PART.NO	DESCRIPTION	REMARK
< CONNECTOR >							
CN001	*1-564-508-11	PLUG, CONNECTOR 6P		D410	8-719-109-89	DIODE RD5.6ESB2	
CN101	1-766-922-11	CONNECTOR, BOARD TO BOARD 18P		D414	8-719-109-97	DIODE RD6.8ESB2	
CN201	*1-564-507-11	PLUG, CONNECTOR 4P		D415	8-719-929-15	DIODE HZS9.1NB2	
CN501	*1-580-798-11	CONNECTOR PIN (DY)		D417	8-719-929-15	DIODE HZS9.1NB2	
CN502	*1-564-508-51	PIN, CONNECTOR 5P		D418	8-719-929-15	DIODE HZS9.1NB2	
CN504	*1-564-509-11	PLUG, CONNECTOR 6P		D419	8-719-929-15	DIODE HZS9.1NB2	
CN506	1-695-915-11	TAB (CONTACT)		D420	8-719-109-97	DIODE RD6.8ES-B2	
CN601	*1-580-843-11	PIN, CONNECTOR (POWER)		D422	8-719-109-97	DIODE RD6.8ES-B2	
CN602	Δ 1-508-765-00	PIN, CONNECTOR (5MM PITCH) 3P		D423	8-719-109-97	DIODE RD6.8ES-B2	
CN603	Δ 1-508-786-00	PIN, CONNECTOR (5MM PITCH) 2P		D424	8-719-929-15	DIODE HZS9.1NB2	
< DIODE >							
D001	8-719-109-89	DIODE RD5.6ESB2		D427	8-719-109-97	DIODE RD6.8ES-B2	
D002	8-719-109-89	DIODE RD5.6ESB2		D430	8-719-109-97	DIODE RD6.8ES-B2	
D003	8-719-057-56	DIODE LS5360HL		D501	8-719-908-03	DIODE GP08D	
D004	8-719-109-89	DIODE RD5.6ESB2		D502	8-719-924-13	DIODE MTZJ-T-77-22B	
D005	8-719-109-89	DIODE RD5.6ESB2		D512	8-719-908-03	DIODE GP08D	
D007	8-719-109-89	DIODE RD5.6ESB2		D513	8-719-908-03	DIODE GP08D	
D008	8-719-991-33	DIODE 1SS133T-77		D514	8-719-908-03	DIODE GP08D	
D009	8-719-109-89	DIODE RD5.6ESB2		D534	8-719-908-03	DIODE GP08D	
D010	8-719-109-89	DIODE RD5.6ESB2		D536	8-719-945-80	DIODE ERC06-15S	
D011	8-719-109-89	DIODE RD5.6ESB2		D539	8-719-928-08	DIODE ERD28-08S	
D012	8-719-914-43	DIODE DAN202K		D541	1-535-303-00	LEAD, JUMPER (5.0MM)	
D014	8-719-058-24	DIODE RB501V-40TE-17		D571	8-719-911-19	DIODE 1SS119-25	
D015	8-719-914-43	DIODE DAN202K		D573	8-719-921-40	DIODE MTZJ-4.7C	
D017	8-719-109-89	DIODE RD5.6ESB2		D601	8-719-510-53	DIODE D4SB60L	
D018	8-719-991-33	DIODE 1SS133T-77		D602	8-719-046-74	DIODE AU-01Z-V1	
D023	8-719-109-89	DIODE RD5.6ESB2		D603	8-719-046-74	DIODE AU-01Z-V1	
D101	8-719-982-24	DIODE MTZJ-33A		D605	8-719-312-10	DIODE RU4AM-T3	
D104	8-719-914-43	DIODE DAN202K	(KV-21C5B/21X5B)	D608	8-719-067-88	DIODE RG1CLF-B1	
D201	8-719-929-15	DIODE HZS9.1NB2		D610	8-719-067-78	DIODE RN3Z-LF014-302	
D202	8-719-914-43	DIODE DAN202K		D613	8-719-911-19	DIODE 1SS119-25	
D204	8-719-109-89	DIODE RD5.6ESB2		D614	8-719-058-38	DIODE FMN-G12S	
D205	8-719-109-89	DIODE RD5.6ESB2		D619	8-719-043-76	DIODE AK04V0	
D206	8-719-109-89	DIODE RD5.6ESB2		D621	8-719-068-00	DIODE ERC04-06SE	
D306	8-719-109-89	DIODE RD5.6ESB2		D626	8-719-068-00	DIODE ERC04-06SE	
D307	8-719-109-89	DIODE RD5.6ESB2		D627	8-719-510-64	DIODE S2LA20F	
D308	8-719-109-72	DIODE RD3.9ES-B2		D628	8-719-059-23	DIODE P6KE200AG23	
D320	8-719-929-15	DIODE HZS9.1NB2		D629	8-719-979-64	DIODE UF4005PKG23	
D402	8-719-109-89	DIODE RD5.6ESB2		D631	8-719-110-31	DIODE RD12ES-B2	
D405	8-719-109-89	DIODE RD5.6ESB2		D632	8-719-510-64	DIODE S2LA20F	
D406	8-719-109-97	DIODE RD6.8ESB2		D633	8-719-109-89	DIODE RD5.6ESB2	
D407	8-719-109-97	DIODE RD6.8ESB2		< FUSE >			
D408	8-719-929-15	DIODE HZS9.1NB2		F601	Δ 1-576-232-21	FUSE (H.B.C.) 5AMP	250V
					Δ *1-533-725-11	HOLDER, FUSE (F601)	



The components identified by shading and marked Δ are critical for safety
 Replace only with the part number specified.

REF. NO.	PART.NO	DESCRIPTION	REMARK	REF. NO.	PART.NO	DESCRIPTION	REMARK
< FERRITE BEAD >				< COIL >			
FB001	1-412-911-11	FERRITE	0UH	L001	1-408-603-31	INDUCTOR	10UH
FB002	1-412-911-11	FERRITE	0UH	L102	1-408-600-31	INDUCTOR	4.7UH
FB601	1-412-911-11	FERRITE	0UH	L103	1-403-686-11	COIL	
FB602	1-412-911-11	FERRITE	0UH	L104	1-535-303-00	LEAD, JUMPER (5.0MM)	
FB605	1-410-397-21	FERRITE	1.1UH	L106	1-408-611-31	INDUCTOR	47UH
FB608	1-412-911-11	FERRITE	0UH	L108	1-410-985-11	INDUCTOR CHIP	0.22UH (KV-21C5B/21X5B)
FB609	1-410-396-41	FERRITE	0.45UH	L109	1-410-789-11	INDUCTOR	0.47UH (KV-21C5B/21X5B)
FB610	1-410-397-21	FERRITE	1.1UH	L201	1-408-591-11	INDUCTOR	1UH
FB611	1-410-397-21	FERRITE	1.1UH	L202	1-408-591-11	INDUCTOR	1UH
FB612	1-535-303-00	LEAD, JUMPER (5.0MM)		L203	1-406-979-11	INDUCTOR	0UH
< IC >				L204	1-408-603-31	INDUCTOR	10UH
IC001	8-759-542-66	IC SAA5497PS/M1A/074	(KV-21C5B/21C5E/21C5K)	L205	1-408-603-31	INDUCTOR	10UH
	8-759-466-49		(KV-21X5B/21X5E/21X5K/21X5L/21X5U)	L301	1-216-295-00	SHORT	0
	8-759-542-68	IC SAA5497PS/M1A/076	(KV-21C5D/21X5A/21X5D)	L302	1-408-611-31	INDUCTOR	47UH
	8-759-542-56	IC SAA5497PS/M1A/075	(KV-21C5R/21X5R)	L303	1-408-609-41	INDUCTOR	33UH
IC002	8-742-014-11	HYB IC SBX1981-51		L401	1-408-611-31	INDUCTOR	47UH
IC003	8-759-468-56	IC MN1381-T(TA)		L402	1-408-611-31	INDUCTOR	47UH
IC004	8-759-432-33	IC ST24W08FM6TR		L403	1-535-303-00	LEAD, JUMPER (5.0MM)	
IC005	8-759-516-41	IC CD4052BCM		L404	1-535-303-00	LEAD, JUMPER (5.0MM)	
IC101	8-759-466-47	IC TDA9818/V1	(KV-21C5B/21X5B)	L405	1-216-295-00	SHORT	0
	8-759-466-79	IC TDA9817/V1	(KV-21C5D/21C5E/21C5K/21C5R/21X5A/21X5D/21X5E/21X5K/21X5L/21X5R/21X5U)	L406	1-216-295-00	SHORT	0
IC201	8-759-442-74	IC TDA7495		L501	1-408-611-31	INDUCTOR	47UH
IC301	8-752-088-38	IC CXA2060BS		L502	1-412-531-31	INDUCTOR	33UH
IC501	8-759-192-71	IC STV9379		L503	1-412-521-31	INDUCTOR	4.7UH
IC531	8-759-450-95	IC LM393N		L532	1-412-553-11	INDUCTOR	3.3MMH
IC603	8-749-920-61	IC SE-135N		L535	1-459-111-00	INDUCTOR	0UH
IC604	8-759-524-82	IC TYA7805CTV		L537	1-459-652-12	HLC	
IC605	8-759-267-25	IC LM2940CT-9.0		L538	1-459-390-00	INDUCTOR	0UH
IC606	8-749-013-75	IC STR-F6654		L540	1-535-303-00	LEAD, JUMPER (5.0MM)	
IC608	8-759-524-82	IC TYA7805CTV		L571	1-412-533-21	INDUCTOR	47UH
IC609	8-759-468-89	IC TOP209P		L602	1-414-187-11	INDUCTOR	47UH
< PHOTO COUPLER >				< TRANSISTOR >			
PH601 Δ	8-749-010-64	PHOTO COUPLER PC123F2		Q004	8-729-216-22	TRANSISTOR 2SA1162-G	
< SOCKET >				Q005	1-801-806-11	TRANSISTOR DTC144EKA	
J201	1-764-606-11	JACK		Q006	1-801-806-11	TRANSISTOR DTC144EKA	
J401	1-766-296-11	CONNECTOR, DUAL SCART		Q007	8-729-422-27	TRANSISTOR 2SD601A-Q	
J402	1-784-967-11	JACK BLOCK, PIN 3P		Q008	8-729-422-27	TRANSISTOR 2SD601A-Q	
J404	1-784-632-11	JACK, PIN 2P		Q009	8-729-422-27	TRANSISTOR 2SD601A-Q	
				Q010	8-729-422-27	TRANSISTOR 2SD601A-Q	
				Q011	1-801-806-11	TRANSISTOR DTC144EKA	
				Q012	8-729-422-27	TRANSISTOR 2SD601A-Q	
				Q014	8-729-422-27	TRANSISTOR 2SD601A-Q	
				Q101	8-729-216-22	TRANSISTOR 2SA1162-G	
				Q107	8-729-022-54	TRANSISTOR 2SC3779C,D-AA	(KV-21C5B/21X5B)



REF. NO.	PART.NO	DESCRIPTION	REMARK	REF. NO.	PART.NO	DESCRIPTION	REMARK
Q109	1-801-806-11	TRANSISTOR DTC144EKA	(KV-21C5B/21X5B)	R023	1-216-295-00	SHORT	0
Q110	1-801-806-11	TRANSISTOR DTC144EKA	(KV-21C5B/21X5B)	R029	1-216-073-00	RES,CHIP	10K 5% 1/10W
Q202	8-729-422-27	TRANSISTOR 2SD601A-Q		R032	1-216-089-00	RES,CHIP	47K 5% 1/10W
Q401	8-729-216-22	TRANSISTOR 2SA1162-G		R034	1-216-065-00	RES,CHIP	4.7K 5% 1/10W
Q405	8-729-120-28	TRANSISTOR 2SC1623-L5L6		R035	1-216-049-00	RES,CHIP	1K 5% 1/10W
Q408	8-729-422-27	TRANSISTOR 2SD601A-Q		R036	1-216-065-00	RES,CHIP	4.7K 5% 1/10W
Q501	8-729-422-27	TRANSISTOR 2SD601A-Q		R038	1-216-073-00	RES,CHIP	10K 5% 1/10W
Q532	8-729-038-83	TRANSISTOR 2SR2251-01-F19		R039	1-216-089-00	RES,CHIP	47K 5% 1/10W
Q533	8-729-041-25	TRANSISTOR S2055N-16E305A		R046	1-216-085-00	RES,CHIP	33K 5% 1/10W
Q535	8-729-119-80	TRANSISTOR 2SC2688-LK		R047	1-216-067-00	RES,CHIP	5.6K 5% 1/10W
Q571	8-729-105-08	TRANSISTOR 2SA1330-06		R048	1-216-081-00	RES,CHIP	22K 5% 1/10W
Q574	8-729-422-27	TRANSISTOR 2SD601A-Q		R049	1-216-057-00	RES,CHIP	2.2K 5% 1/10W
Q575	1-801-806-11	TRANSISTOR DTC144EKA		R050	1-216-041-00	RES,CHIP	470 5% 1/10W
Q576	8-729-422-27	TRANSISTOR 2SD601A-Q		R051	1-216-049-00	RES,CHIP	1K 5% 1/10W
Q601	8-729-216-22	TRANSISTOR 2SA1162-G		R053	1-216-065-00	RES,CHIP	4.7K 5% 1/10W
< RESISTOR >				R054	1-216-041-00	RES,CHIP	470 5% 1/10W
JR012	1-216-296-00	SHORT	0 (KV-21C5D/21C5E/21C5K/21C5R) (KV-21X5A/21X5D/21X5E/21X5K/ 21X5L/21X5R/21X5U)	R055	1-216-081-00	RES,CHIP	22K 5% 1/10W
JR023	1-216-296-00	SHORT	0	R056	1-216-105-00	RES,CHIP	220K 5% 1/10W
JR031	1-216-295-00	SHORT	0	R057	1-216-075-00	RES,CHIP	12K 5% 1/10W
JR403	1-216-073-00	RES,CHIP	10K 5% 1/10W	R058	1-216-063-91	RES,CHIP	3.9K 5% 1/10W
JR409	1-216-295-00	SHORT	0	R059	1-216-089-00	RES,CHIP	47K 5% 1/10W
JR411	1-216-295-00	SHORT	0	R060	1-216-174-00	RES,CHIP	100 5% 1/8W
JR412	1-216-295-71	CONDUCTOR CHIP		R061	1-216-174-00	RES,CHIP	100 5% 1/8W
JR610	1-216-296-00	SHORT	0	R062	1-216-033-00	RES,CHIP	220 5% 1/10W
JR616	1-216-296-00	SHORT	0	R063	1-216-065-00	RES,CHIP	4.7K 5% 1/10W
JR617	1-216-296-00	SHORT	0				(KV-21C5B/21X5B)
JW220	8-719-109-89	DIODE RD5.6ESB2		R064	1-216-065-00	RES,CHIP	4.7K 5% 1/10W
R001	1-216-025-00	RES,CHIP	100 5% 1/10W				(KV-21C5B/21X5B)
R002	1-216-025-00	RES,CHIP	100 5% 1/10W	R065	1-216-025-00	RES,CHIP	100 5% 1/10W
R003	1-216-065-00	RES,CHIP	4.7K 5% 1/10W	R066	1-216-065-00	RES,CHIP	4.7K 5% 1/10W
R004	1-216-065-00	RES,CHIP	4.7K 5% 1/10W	R067	1-216-065-00	RES,CHIP	4.7K 5% 1/10W
R005	1-216-065-00	RES,CHIP	4.7K 5% 1/10W	R068	1-216-073-00	RES,CHIP	10K 5% 1/10W
R007	1-216-065-00	RES,CHIP	4.7K 5% 1/10W	R069	1-216-049-00	RES,CHIP	1K 5% 1/10W
R008	1-216-025-00	RES,CHIP	100 5% 1/10W	R070	1-216-081-00	RES,CHIP	22K 5% 1/10W
R009	1-216-025-00	RES,CHIP	100 5% 1/10W	R071	1-216-214-00	RES,CHIP	4.7K 5% 1/8W
R010	1-216-025-00	RES,CHIP	100 5% 1/10W	R072	1-216-097-00	RES,CHIP	100K 5% 1/10W
R011	1-216-025-00	RES,CHIP	100 5% 1/10W	R073	1-216-097-00	RES,CHIP	100K 5% 1/10W
R012	1-247-807-31	CARBON	100 5% 1/4W	R075	1-216-069-00	RES,CHIP	6.8K 5% 1/10W
R013	1-216-214-00	RES,CHIP	4.7K 5% 1/8W	R077	1-216-083-00	RES,CHIP	27K 5% 1/10W
R014	1-216-057-00	RES,CHIP	2.2K 5% 1/10W	R082	1-216-053-00	RES,CHIP	1.5K 5% 1/10W
R015	1-216-049-00	RES,CHIP	1K 5% 1/10W	R083	1-216-031-00	RES,CHIP	180 5% 1/10W
R017	1-249-429-11	CARBON	10K 5% 1/4W	R084	1-216-053-00	RES,CHIP	1.5K 5% 1/10W
R019	1-216-053-00	RES,CHIP	1.5K 5% 1/10W	R085	1-216-031-00	RES,CHIP	180 5% 1/10W
				R086	1-216-053-00	RES,CHIP	1.5K 5% 1/10W
				R087	1-216-180-00	RES,CHIP	180 5% 1/8W
				R088	1-216-065-00	RES,CHIP	4.7K 5% 1/10W
				R093	1-216-230-00	RES,CHIP	22K 5% 1/8W



REF. NO.	PART.NO	DESCRIPTION	REMARK	REF. NO.	PART.NO	DESCRIPTION	REMARK
R094	1-216-057-00	RES,CHIP	2.2K 5% 1/10W	R201	1-260-091-11	CARBON	220 5% 1/2W
R095	1-216-025-00	RES,CHIP	100 5% 1/10W	R204	1-247-863-91	CARBON	22K 5% 1/4W
R096	1-247-807-31	CARBON	100 5% 1/4W	R205	1-260-091-11	CARBON	220 5% 1/2W
R097	1-247-807-31	CARBON	100 5% 1/4W	R206	1-216-085-00	RES,CHIP	33K 5% 1/10W
R098	1-247-807-31	CARBON	100 5% 1/4W	R207	1-216-295-00	SHORT	0
R099	1-247-807-31	CARBON	100 5% 1/4W	R209	1-216-065-00	RES,CHIP	4.7K 5% 1/10W
R101	1-216-049-00	RES,CHIP	1K 5% 1/10W	R211	1-215-873-21	METAL OXIDE	4.7K 5% 1W F
R106	1-215-900-11	METAL OXIDE	22K 5% 2W F	R213	1-216-093-00	RES,CHIP	68K 5% 1/10W
R110	1-216-206-00	RES,CHIP	2.2K 5% 1/8W (KV-21C5B/21X5B)	R301	1-216-025-00	RES,CHIP	100 5% 1/10W
R111	1-216-057-00	RES,CHIP	2.2K 5% 1/10W (KV-21C5B/21X5B)	R302	1-216-073-00	RES,CHIP	10K 5% 1/10W
R112	1-216-057-00	RES,CHIP	2.2K 5% 1/10W (KV-21C5B/21X5B)	R303	1-216-073-00	RES,CHIP	10K 5% 1/10W
R116	1-249-437-11	CARBON	47K 5% 1/4W	R304	1-216-073-00	RES,CHIP	10K 5% 1/10W
R120	1-216-037-00	RES,CHIP	330 5% 1/10W	R305	1-412-002-31	INDUCTOR CHIP	4.7UH
R121	1-216-025-00	RES,CHIP	100 5% 1/10W	R306	1-216-206-00	RES,CHIP	2.2K 5% 1/8W
R122	1-216-025-00	RES,CHIP	100 5% 1/10W	R309	1-216-675-11	METAL CHIP	10K 0.50% 1/10W
R127	1-216-031-00	RES,CHIP	180 5% 1/10W (KV-21C5B/21X5B)	R310	1-216-022-00	RES,CHIP	75 5% 1/10W
R128	1-216-065-00	RES,CHIP	4.7K 5% 1/10W (KV-21C5B/21X5B)	R311	1-216-029-00	RES,CHIP	150 5% 1/10W
R129	1-216-063-91	RES,CHIP	3.9K 5% 1/10W (KV-21C5B/21X5B)	R313	1-216-025-00	RES,CHIP	100 5% 1/10W
R133	1-216-295-00	SHORT	0 (KV-21C5D/21C5E/21C5K/21C5R) (KV-21X5A/21X5D/21X5E/21X5K/ 21X5L/21X5R/21X5U)	R314	1-216-025-00	RES,CHIP	100 5% 1/10W
R142	1-216-295-00	SHORT	0	R315	1-216-075-00	RES,CHIP	12K 5% 1/10W
R143	1-216-025-00	RES,CHIP	100 5% 1/10W (KV-21C5B/21X5B)	R316	1-216-025-00	RES,CHIP	100 5% 1/10W
R143	1-216-031-91	RES,CHIP	180 5% 1/10W (KV-21C5D/21C5E/21C5K/21C5R) (KV-21X5A/21X5D/21X5E/21X5K/ 21X5L/21X5R/21X5U)	R317	1-216-049-00	RES,CHIP	1K 5% 1/10W
R144	1-216-079-00	RES,CHIP	18K 5% 1/10W	R318	1-216-025-00	RES,CHIP	100 5% 1/10W
R145	1-216-212-00	RES,CHIP	3.9K 5% 1/8W	R319	1-216-025-00	RES,CHIP	100 5% 1/10W
R147	1-216-017-91	RES,CHIP	47 5% 1/10W (KV-21C5B/21X5B)	R320	1-216-025-00	RES,CHIP	100 5% 1/10W
R148	1-216-174-00	RES,CHIP	100 5% 1/8W (KV-21C5B/21X5B)	R321	1-216-025-00	RES,CHIP	100 5% 1/10W
R149	1-216-049-00	RES,CHIP	1K 5% 1/10W (KV-21C5B/21X5B)	R322	1-216-025-00	RES,CHIP	100 5% 1/10W
R151	1-216-049-00	RES,CHIP	1K 5% 1/10W	R323	1-216-025-00	RES,CHIP	100 5% 1/10W
R152	1-216-025-00	RES,CHIP	100 5% 1/10W (KV-21C5B/21X5B)	R324	1-412-002-31	INDUCTOR CHIP	4.7UH
R153	1-216-180-00	RES,CHIP	180 5% 1/8W	R325	1-412-002-31	INDUCTOR CHIP	4.7UH
R154	1-216-238-91	RES,CHIP	47K 5% 1/8W	R326	1-216-129-00	RES,CHIP	2.2M 5% 1/10W
R155	1-216-089-00	RES,CHIP	47K 5% 1/10W	R331	1-216-057-00	RES,CHIP	2.2K 5% 1/10W
				R332	1-216-057-00	RES,CHIP	2.2K 5% 1/10W
				R333	1-216-057-00	RES,CHIP	2.2K 5% 1/10W
				R334	1-216-025-00	RES,CHIP	100 5% 1/10W
				R335	1-216-025-00	RES,CHIP	100 5% 1/10W
				R338	1-216-049-00	RES,CHIP	1K 5% 1/10W
				R401	1-216-113-00	RES,CHIP	470K 5% 1/10W
				R402	1-216-295-71	CONDUCTOR CHIP	
				R403	1-216-041-00	RES,CHIP	470 5% 1/10W
				R404	1-216-113-00	RES,CHIP	470K 5% 1/10W
				R405	1-216-295-00	SHORT	0
				R406	1-216-113-00	RES,CHIP	470K 5% 1/10W
				R408	1-216-022-00	RES,CHIP	75 5% 1/10W
				R409	1-216-025-00	RES,CHIP	100 5% 1/10W
				R410	1-216-025-00	RES,CHIP	100 5% 1/10W
				R411	1-216-022-00	RES,CHIP	75 5% 1/10W
				R412	1-216-025-00	RES,CHIP	100 5% 1/10W



REF. NO.	PART.NO	DESCRIPTION	REMARK	REF. NO.	PART.NO	DESCRIPTION	REMARK
R413	1-216-295-00	SHORT	0	R507	1-216-349-00	METAL OXIDE	1 5% 1W F
R414	1-216-022-00	RES,CHIP	75 5% 1/10W	R508	1-216-667-11	METAL CHIP	4.7K 0.50% 1/10W
R415	1-216-022-00	RES,CHIP	75 5% 1/10W	R509	1-216-059-00	RES,CHIP	2.7K 5% 1/10W
R417	1-247-804-11	CARBON	75 5% 1/4W	R510	1-216-081-00	RES,CHIP	22K 5% 1/10W
		(KV-21C5B/21C5D/21C5E/21C5K/21C5R)		R512	1-249-382-11	CARBON	1.2 5% 1/4W F
		(KV-21X5A/21X5B/21X5D/21X5E/21X5K/21X5R)					
	1-247-698-11	CARBON	68 5% 1/4W	R514	1-249-377-11	CARBON	0.47 5% 1/4W F
		(KV-21X5L/21X5U)		R515	1-249-377-11	CARBON	0.47 5% 1/4W F
R418	1-249-413-11	CARBON	470 5% 1/4W	R516	1-249-493-11	CARBON	56K 5% 1/2W
		(KV-21C5B/21C5D/21C5E/21C5K/21C5R)		R517	1-249-436-11	CARBON	39K 5% 1/4W
		(KV-21X5A/21X5B/21X5D/21X5E/21X5K/21X5R)		R518	1-216-065-00	RES,CHIP	4.7K 5% 1/10W
	1-249-414-11	CARBON	560 5% 1/4W				
		(KV-21X5L/21X5U)		R519	1-216-121-91	RES,CHIP	1M 5% 1/10W
R419	1-216-022-00	RES,CHIP	75 5% 1/10W	R520	1-215-883-11	METAL OXIDE	33 5% 2W F
R420	1-216-041-00	RES,CHIP	470 5% 1/10W	R522	1-216-097-00	RES,CHIP	100K 5% 1/10W
R421	1-216-113-00	RES,CHIP	470K 5% 1/10W	R523	1-216-117-00	RES,CHIP	680K 5% 1/10W
R422	1-216-295-00	SHORT	0	R524	1-216-085-00	RES,CHIP	33K 5% 1/10W
R425	1-216-077-00	RES,CHIP	15K 5% 1/10W				
R426	1-216-073-00	RES,CHIP	10K 5% 1/10W	R525	1-216-057-00	RES,CHIP	2.2K 5% 1/10W
R427	1-216-113-00	RES,CHIP	470K 5% 1/10W	R526	1-216-089-00	RES,CHIP	47K 5% 1/10W
R429	1-216-041-00	RES,CHIP	470 5% 1/10W	R527	1-216-075-00	RES,CHIP	12K 5% 1/10W
R430	1-216-113-00	RES,CHIP	470K 5% 1/10W	R528	1-216-246-00	RES,CHIP	100K 5% 1/8W
R431	1-216-295-00	SHORT	0	R529	1-216-073-00	RES,CHIP	10K 5% 1/10W
R432	1-216-113-00	RES,CHIP	470K 5% 1/10W				
R435	1-216-022-00	RES,CHIP	75 5% 1/10W	R530	1-216-085-00	RES,CHIP	33K 5% 1/10W
R436	1-216-041-00	RES,CHIP	470 5% 1/10W	R531	1-216-057-00	RES,CHIP	2.2K 5% 1/10W
R437	1-216-029-00	RES,CHIP	150 5% 1/10W	R532	1-216-065-00	RES,CHIP	4.7K 5% 1/10W
R439	1-216-041-00	RES,CHIP	470 5% 1/10W	R533	1-216-081-00	RES,CHIP	22K 5% 1/10W
R440	1-216-113-00	RES,CHIP	470K 5% 1/10W	R539	1-216-049-00	RES,CHIP	1K 5% 1/10W
R441	1-216-295-00	SHORT	0				
R442	1-216-077-00	RES,CHIP	15K 5% 1/10W	R540	1-215-887-00	METAL OXIDE	150 5% 2W F
R443	1-216-073-00	RES,CHIP	10K 5% 1/10W	R541	1-216-105-00	RES,CHIP	220K 5% 1/10W
R445	1-216-178-00	RES,CHIP	150 5% 1/8W	R542	1-216-089-00	RES,CHIP	47K 5% 1/10W
R446	1-216-113-00	RES,CHIP	470K 5% 1/10W	R543	1-216-089-00	RES,CHIP	47K 5% 1/10W
R447	1-216-295-71	CONDUCTOR CHIP		R545	1-216-129-91	RES,CHIP	2.2M 5% 1/10W
R448	1-216-113-00	RES,CHIP	470K 5% 1/10W				
R449	1-216-295-71	CONDUCTOR CHIP		R546	1-249-401-11	CARBON	47 5% 1/4W F
R450	1-216-041-00	RES,CHIP	470 5% 1/10W	R547	1-535-143-71	LEAD, JUMPER (7.5MM)	
R454	1-216-041-00	RES,CHIP	470 5% 1/10W	R548	1-212-849-00	FUSIBLE	4.7 5% 1/4W F
R457	1-216-025-00	RES,CHIP	100 5% 1/10W	R549	1-216-371-00	METAL OXIDE	1.5 5% 2W F
R459	1-247-807-31	CARBON	100 5% 1/4W	R551	1-215-873-00	METAL OXIDE	4.7K 5% 1W F
R460	1-249-403-11	CARBON	68 5% 1/4W				
R501	1-216-081-00	RES,CHIP	22K 5% 1/10W	R552	1-216-061-00	RES,CHIP	3.3K 5% 1/10W
R502	1-216-097-00	RES,CHIP	100K 5% 1/10W	R553	1-249-381-11	CARBON	1 5% 1/4W F
R503	1-215-888-00	METAL OXIDE	220 5% 2W F	R554	1-216-109-91	RES,CHIP	330K 5% 1/10W
R504	1-249-385-11	CARBON	2.2 5% 1/4W F	R571	1-249-417-11	CARBON	1K 5% 1/4W F
R505	1-216-667-11	METAL CHIP	4.7K 0.50% 1/10W	R572	1-216-369-00	METAL OXIDE	1 5% 2W F
R506	1-216-059-00	RES,CHIP	2.7K 5% 1/10W				
				R573	1-216-101-00	RES,CHIP	150K 5% 1/10W
				R574	1-216-065-00	RES,CHIP	4.7K 5% 1/10W
				R575	1-216-097-00	RES,CHIP	100K 5% 1/10W
				R576	1-249-399-11	CARBON	33 5% 1/4W
				R581	1-216-089-00	RES,CHIP	47K 5% 1/10W
				R582	1-216-089-00	RES,CHIP	47K 5% 1/10W
				R583	1-216-081-00	RES,CHIP	22K 5% 1/10W



The components identified by shading and marked Δ are critical for safety. Replace only with the part number specified.

REF. NO.	PART.NO	DESCRIPTION	REMARK
R588	1-216-051-00	RES,CHIP	1.2K 5% 1/10W
R589	1-216-097-00	RES,CHIP	100K 5% 1/10W
R590	1-216-073-00	RES,CHIP	10K 5% 1/10W
R591	1-215-892-11	METAL OXIDE	1K 5% 2W F
R593	1-249-439-11	CARBON	68K 5% 1/4W
R594	1-216-057-00	RES,CHIP	2.2K 5% 1/10W
R595	1-249-377-11	CARBON	0.47 5% 1/4W F
R602	1-202-961-11	CEMENTED	1.8 5% 10W
R603	1-202-933-61	FUSIBLE	0.1 10% 1/2W F
R607 Δ	1-202-961-11	CEMENTED	1.8 5% 10W
R608	1-215-927-00	METAL OXIDE	47K 5% 3W F
R611	1-249-415-11	CARBON	680 5% 1/4W
R613 Δ	1-240-030-91	METAL	4.7M 5% 1/2W
R614 Δ	1-240-030-91	METAL	4.7M 5% 1/2W
R615	1-249-422-11	CARBON	2.7K 5% 1/4W
R616	1-216-393-00	METAL OXIDE	2.2 5% 3W F
R617	1-249-405-11	CARBON	100 5% 1/4W F
R619	1-216-065-00	RES,CHIP	4.7K 5% 1/10W
R622	1-249-401-11	CARBON	47 5% 1/4W
R627	1-249-385-11	CARBON	4.7 5% 1/4W F
R628	1-247-791-91	CARBON	22 5% 1/4W
R652	1-216-393-00	METAL OXIDE	2.2 5% 3W F
R653	1-216-393-00	METAL OXIDE	2.2 5% 3W F
R658	1-215-929-11	METAL OXIDE	100K 5% 3W F
R659	1-216-383-11	METAL OXIDE	0.33 5% 3W F
R660	1-216-384-11	METAL OXIDE	0.39 5% 3W F
R661	1-247-843-11	CARBON	3.3K 5% 1/4W
R662	1-215-929-11	METAL OXIDE	100K 5% 3W F
R664	1-249-417-11	CARBON	1K 5% 1/4W
R665	1-215-877-11	METAL OXIDE	22K 5% 1W F
R667	1-215-927-00	METAL OXIDE	47K 5% 3W F
< VARIABLE RESISTOR >			
RV101	1-241-765-11	RES, ADJ, CARBON 22K	(KV-21C5B/21X5B)
< RELAY >			
RY601 Δ	1-755-245-11	RELAY, AC POWER	
< SWITCH >			
S001	1-571-532-21	SWITCH, TACTIL	
S002	1-571-532-21	SWITCH, TACTIL	
S003	1-571-532-21	SWITCH, TACTIL	
S004	1-571-532-21	SWITCH, TACTIL	
S005	1-571-532-21	SWITCH, TACTIL	
S006	1-571-532-21	SWITCH, TACTIL	
S601 Δ	1-571-433-21	SWITCH, PUSH (AC POWER)	

REF. NO.	PART.NO	DESCRIPTION	REMARK
< TRANSFORMER >			
T511 Δ	1-453-279-11	TRANSFORMER ASSY, FLYBACK NX-1747/U2B	
T531	1-437-195-11	TRANSFORMER, HORIZONTAL DRIVE	
T601 Δ	1-433-411-11	TRANSFORMER, LINE FILTER	
T602	1-431-732-11	TRANSFORMER, CONVERTER (SRT)	
T603 Δ	1-431-777-11	TRANSFORMER, CONVERTER	
< THERMISTOR >			
THP601 Δ	1-808-059-31	THERMISTOR, POSITIVE	
< TUNER >			
TU101	1-693-418-11	TUNER (TELE9-001A)	(KV-21C5B/21X5B)
	8-598-432-00	TUNER BTP-AC411	(KV-21C5D/21C5E/21C5K/21C5R/21X5A/21X5D/21X5E/21X5K/21X5R/21X5L)
	8-598-464-00	TUNER BTP-AU611	(KV-21X5U)
< CRYSTAL >			
X001	1-578-774-11	VIBRATOR, CRYSTAL	
X302	1-567-505-11	OSCILLATOR, CRYSTAL	
X303	1-567-504-11	OSCILLATOR, CRYSTAL	

	*A-1638-118-A	C BOARD, COMPLETE	

< CAPACITOR >			
C701	1-102-114-00	CERAMIC	470PF 10% 50V
C702	1-102-109-91	CERAMIC	180PF 10% 50V
C703	1-102-109-91	CERAMIC	180PF 10% 50V
C708	1-162-114-00	CERAMIC	0.0047MF 2KV
C710	1-136-189-00	FILM	10MF 10% 250V
C712	1-102-109-91	CERAMIC	180PF 10% 50V
C714	1-126-967-11	ELECT	47MF 20% 16V
C717	1-102-114-00	CERAMIC	470PF 10% 50V
C718	1-102-114-00	CERAMIC	470PF 10% 50V
C719	1-102-114-00	CERAMIC	470PF 10% 50V
< CONNECTOR >			
CN702	1-695-915-11	TAB (CONTACT)	
CN703	*1-564-509-11	PLUG, CONNECTOR 6P	
CN706	1-695-915-21	TAB (CONTACT)	
CN707	*1-564-508-51	PLUG, CONNECTOR 5P	

The components identified by shading and marked Δ are critical for safety. Replace only with the part number specified.

C **S1**

REF. NO.	PART.NO	DESCRIPTION	REMARK	REF. NO.	PART.NO	DESCRIPTION	REMARK
< DIODE >				R707	1-249-411-11	CARBON 330 5%	1/4W
D701	8-719-109-89	DIODE RD5.6ESB2		R708	1-249-408-11	CARBON 180 5%	1/4W
D702	8-719-991-33	DIODE 1SS133T-77		R711	1-249-427-11	CARBON 6.8K 5%	1/4W
D703	8-719-991-33	DIODE 1SS133T-77		R712	1-260-099-11	CARBON 1K 5%	1/2W
D704	8-719-991-33	DIODE 1SS133T-77		R713	1-249-439-11	CARBON 68K 5%	1/4W
D705	8-719-991-33	DIODE 1SS133T-77		R714	1-215-899-11	METAL OXIDE 15K 5%	2W F
D706	8-719-991-33	DIODE 1SS133T-77		R715	1-535-143-11	LEAD, JUMPER (10.0MM)	
D707	8-719-991-33	DIODE 1SS133T-77		R716	1-247-815-91	CARBON 220 5%	1/4W
D708	1-535-143-61	LEAD, JUMPER (5.0MM)		R717	1-249-411-11	CARBON 330 5%	1/4W
D709	8-719-991-33	DIODE 1SS133T-77		R718	1-202-814-11	SOLID 33K 10%	1/2W
D710	8-719-991-33	DIODE 1SS133T-77		R719	1-249-408-11	CARBON 180 5%	1/4W
D711	1-216-349-00	METAL OXIDE 1 5%	1W F	R720	1-249-427-11	CARBON 6.8K 5%	1/4W
D712	8-719-991-33	DIODE 1SS133T-77		R721	1-535-143-61	LEAD, JUMPER (5.0MM)	
D713	1-535-303-00	LEAD, JUMPER (5.0MM)		R722	1-202-848-00	SOLID 680K 10%	1/2W
D714	8-719-991-33	DIODE 1SS133T-77		R723	1-535-143-11	LEAD, JUMPER (10.0MM)	
D715	1-535-143-61	LEAD, JUMPER (5.0MM)		R726	1-260-099-11	CARBON 1K 5%	1/2W
D716	8-719-991-33	DIODE 1SS133T-77		R727	1-247-815-91	CARBON 220 5%	1/4W
D718	8-719-991-33	DIODE 1SS133T-77		R728	1-216-351-00	METAL OXIDE 1.5 5%	1W F
D719	1-535-143-61	LEAD, JUMPER (5.0MM)		R729	1-249-411-11	CARBON 330 5%	1/4W
< CRT SOCKET >				R730	1-249-408-11	CARBON 180 5%	1/4W
J701	Δ 1-251-595-11	SOCKET, CRT		R731	1-249-427-11	CARBON 6.8K 5%	1/4W
< COIL >				R734	1-247-807-31	CARBON 100 5%	1/4W
L704	1-414-186-31	MICRO INDUCTOR 33UH		R736	1-215-899-11	METAL OXIDE 15K 5%	2W F
< TRANSISTOR >				R737	1-247-891-00	CARBON 330K 5%	1/4W
Q702	8-729-119-78	TRANSISTOR 2SC2785-HFE		R739	1-535-143-11	LEAD, JUMPER (10.0MM)	
Q703	8-729-046-28	TRANSISTOR BF420-126		R741	1-202-549-00	SOLID 100 20%	1/2W
Q704	8-729-200-17	TRANSISTOR 2SA1091-0		R743	1-535-143-61	LEAD, JUMPER (5.0MM)	
Q705	8-729-119-78	TRANSISTOR 2SC2785-HFE		R746	1-249-417-11	CARBON 1K 5%	1/4W
Q706	8-729-046-28	TRANSISTOR BF420-126		R750	1-249-417-11	CARBON 1K 5%	1/4W
Q707	8-729-200-17	TRANSISTOR 2SA1091-0		R751	1-249-417-11	CARBON 1K 5%	1/4W
Q708	8-729-119-78	TRANSISTOR 2SC2785-HFE		< VARIABLE RESISTOR >			
Q709	8-729-046-28	TRANSISTOR BF420-126		RV702	1-241-656-21	RES, ADJ, METAL FILM 110M	
Q710	8-729-200-17	TRANSISTOR 2SA1091-0		*****			
Q712	8-729-046-28	TRANSISTOR BF420-126		*A-1652-056-A	S1 BOARD, COMPLETE	(KV-21C5B/21X5B)	
Q713	8-729-046-28	TRANSISTOR BF420-126			*****		
< RESISTOR >				*A-1652-053-A	S1 BOARD, COMPLETE	(KV-21C5D/21C5R/21X5A/21X5D/21X5R)	
R701	1-247-895-91	CARBON 470K 5%	1/4W		*****		
R702	1-215-899-11	METAL OXIDE 15K 5%	2W F	*A-1652-052-A	S1 BOARD, COMPLETE	(KV-21C5E/21C5K/21X5E/21X5K/21X5L/21X5U)	
R703	1-535-143-61	LEAD, JUMPER (5.0MM)		< CAPACITOR >			
R705	1-260-099-11	CARBON 1K 5%	1/2W	C1103	1-164-232-11	CERAMIC CHIP 0.01MF	10% 50V
R706	1-247-815-91	CARBON 220 5%	1/4W	C1106	1-164-232-11	CERAMIC CHIP 0.01MF	10% 50V
				C1107	1-164-232-11	CERAMIC CHIP 0.01MF	10% 50V
				C1108	1-164-232-11	CERAMIC CHIP 0.01MF	10% 50V
				C1109	1-104-664-11	ELECT 47MF	20% 25V

S1

REF. NO.	PART. NO	DESCRIPTION	REMARK	REF. NO.	PART. NO	DESCRIPTION	REMARK
C1112	1-163-001-11	CERAMIC CHIP 220PF	10% 50V			< FILTER >	
C1113	1-104-664-11	ELECT 47MF	20% 25V				
C1114	1-163-001-11	CERAMIC CHIP 220PF	10% 50V	CF1101	1-409-327-00	TRAP, CERAMIC (6.5MHZ)	(KV-21C5B/21X5B)
C1115	1-104-664-11	ELECT 47MF	20% 25V			< CONNECTOR >	
C1118	1-162-637-11	CERAMIC CHIP 0.47MF	16V				
C1120	1-164-005-11	CERAMIC CHIP 0.47MF	25V	CN1101	1-766-925-11	CONNECTOR, BOARD TO BOARD 18P	
C1122	1-104-664-11	ELECT 47MF	20% 25V			< DIODE >	
C1123	1-164-004-11	CERAMIC CHIP 0.1MF	10% 25V				
C1124	1-163-251-11	CERAMIC CHIP 100PF	5% 50V	D1101	8-719-066-72	DIODE BB135	(KV-21C5B/21C5E/21C5K) (KV-21X5B/21X5E/21X5K/ 21X5L/21X5U)
C1127	1-163-239-11	CERAMIC CHIP 33PF	5% 50V		1-216-295-00	SHORT 0	(KV-21C5D/21C5R/21X5A/ 21X5D/21X5R)
	1-163-235-11	CERAMIC CHIP 22PF	5% 50V (KV-21C5D/21C5R) (KV-21X5A/21X5D/21X5R)			< FERRITE BEAD >	
C1128	1-163-239-11	CERAMIC CHIP 33PF	5% 50V	FB1101	1-410-396-41	FERRITE 0.45UH	
C1129	1-163-989-11	CERAMIC CHIP 0.033MF	10% 25V (KV-21C5B/21C5E/21C5K) (KV-21X5B/21X5E/21X5K/ 21X5L/21X5U)	FB1102	1-410-396-41	FERRITE 0.45UH	
				FB1103	1-410-396-41	FERRITE 0.45UH	
				FB1104	1-410-396-41	FERRITE 0.45UH	
				FB1105	1-410-396-41	FERRITE 0.45UH	
C1130	1-110-501-11	CERAMIC CHIP 0.33MF	10% 16V (KV-21C5B/21C5E/21C5K) (KV-21X5B/21X5E/21X5K/ 21X5L/21X5U)	FB1110	1-412-002-31	INDUCTOR CHIP 4.7UH	
				FB1111	1-412-002-31	INDUCTOR CHIP 4.7UH	
				FB1112	1-412-002-31	INDUCTOR CHIP 4.7UH	
				FB1113	1-412-002-31	INDUCTOR CHIP 4.7UH	(KV-21C5B/21X5B)
C1131	1-164-005-11	CERAMIC CHIP 0.47MF	25V (KV-21C5B/21C5D/21C5R) (KV-21X5A/21X5B/21X5D/ 21X5R)			< IC >	
				IC1101	8-759-466-48	IC TDA9875P	(KV-21C5B/21C5E/21C5K) (KV-21X5B/21X5E/21X5K/ 21X5L/21X5U)
C1132	1-104-664-11	ELECT 47MF	20% 25V		8-759-522-62	IC TDA9870	(KV-21C5D/21C5R) (KV-21X5A/21X5D/21X5R)
C1133	1-164-004-11	CERAMIC CHIP 0.1MF	10% 25V				
C1135	1-163-117-00	CERAMIC CHIP 100PF	5% 50V (KV-21C5B/21X5B)	IC1102	8-759-100-96	IC UPC4558G2	
				IC1103	8-759-394-57	IC PST593C-MMP-4P	
C1137	1-104-664-11	ELECT 47MF	20% 25V (KV-21C5B/21X5B)			< COIL >	
C1138	1-163-109-00	CERAMIC CHIP 47PF	5% 50V (KV-21C5B/21X5B)	L1101	1-408-596-31	INDUCTOR 2.7UH	(KV-21C5B/21C5E/21C5K) (KV-21X5B/21X5E/21X5K/ 21X5L/21X5U)
C1143	1-163-005-11	CERAMIC CHIP 470PF	10% 50V				
C1144	1-163-005-11	CERAMIC CHIP 470PF	10% 50V	L1113	1-408-600-31	INDUCTOR 5.6UH	(KV-21C5B/21X5B)
C1145	1-163-077-00	CERAMIC CHIP 0.1MF	10% 25V	L1114	1-410-671-31	INDUCTOR 47UH	
C1146	1-164-005-11	CERAMIC CHIP 0.47MF	25V	L1115	1-408-599-31	INDUCTOR 4.7UH	
C1147	1-164-005-11	CERAMIC CHIP 0.47MF	25V	L1116	1-408-599-31	INDUCTOR 4.7UH	
C1148	1-164-005-11	CERAMIC CHIP 0.47MF	25V	L1117	1-410-671-31	INDUCTOR 47UH	(KV-21C5B/21X5B)
C1149	1-126-960-11	ELECT 1MF	20% 50V			< TRANSISTOR >	
C1150	1-126-960-11	ELECT 1MF	20% 50V	Q1112	8-729-620-06	TRANSISTOR 2SC3052-EF	(KV-21C5B/21X5B)
C1151	1-104-664-11	ELECT 47MF	20% 25V	Q1113	8-729-620-06	TRANSISTOR 2SC3052-EF	(KV-21C5B/21X5B)
C1152	1-164-004-11	CERAMIC CHIP 0.1MF	10% 25V				

REF. NO.	PART.NO	DESCRIPTION	REMARK	REF. NO.	PART.NO	DESCRIPTION	REMARK
Q1114	8-729-216-22	TRANSISTOR 2SA1162-G	(KV-21C5B/21X5B)	R1167	1-216-025-00	RES,CHIP 100 5%	1/10W (KV-21C5B/21X5B)
Q1115	8-729-620-06	TRANSISTOR 2SC3052-EF	(KV-21C5B/21X5B)	R1168	1-216-033-00	RES,CHIP 220 5%	1/10W (KV-21C5B/21X5B)
< RESISTOR >				R1169	1-216-049-00	RES,CHIP 1K 5%	1/10W (KV-21C5B/21X5B)
JR1105	1-216-295-00	SHORT	0	R1170	1-216-001-00	RES,CHIP 10 5%	1/10W (KV-21C5B/21X5B)
JR1112	1-216-295-00	SHORT	0	R1171	1-216-045-00	RES,CHIP 680 5%	1/10W (KV-21C5B/21X5B)
JR1113	1-216-295-00	SHORT	0	R1172	1-216-190-00	RES,CHIP 470 5%	1/8W (KV-21C5B/21X5B)
R1101	1-216-073-00	RES,CHIP	10K 5% 1/10W	R1173	1-216-049-00	RES,CHIP 1K 5%	1/10W (KV-21C5B/21X5B)
R1102	1-216-073-00	RES,CHIP	10K 5% 1/10W	R1174	1-216-085-00	RES,CHIP 33K 5%	1/10W
R1103	1-216-035-00	RES,CHIP	270 5% 1/10W	R1175	1-216-085-00	RES,CHIP 33K 5%	1/10W
R1105	1-216-035-00	RES,CHIP	270 5% 1/10W	R1176	1-216-085-00	RES,CHIP 33K 5%	1/10W
R1108	1-216-057-00	RES,CHIP	2.2K 5% 1/10W (KV-21C5B/21X5B)	R1177	1-216-085-00	RES,CHIP 33K 5%	1/10W
R1110	1-216-025-00	RES,CHIP	100 5% 1/10W	R1178	1-216-073-00	RES,CHIP 10K 5%	1/10W
R1111	1-216-025-00	RES,CHIP	100 5% 1/10W	< CRYSTAL >			
R1113	1-216-073-00	RES,CHIP	10K 5% 1/10W	X1101	1-767-813-21	VIBRATOR, CRYSTAL	
R1116	1-216-689-11	METAL CHIP	39K 0.50% 1/10W (KV-21C5B/21C5E/21C5K) (KV-21X5B/21X5E/21X5K/ 21X5L/21X5U)	*****			
	1-216-295-00	SHORT	0 (KV-21C5D/21C5R) (KV-21X5A/21X5D/21X5R)				
R1117	1-216-073-00	RES,CHIP	10K 5% 1/10W (KV-21C5B/21C5E/21C5K) (KV-21X5B/21X5E/21X5K/ 21X5L/21X5U)				
R1118	1-216-689-11	RES,CHIP	39K 5% 1/10W (KV-21C5B/21C5E/21C5K) (KV-21X5B/21X5E/21X5K/ 21X5L/21X5U)				
R1121	1-216-065-00	RES,CHIP	4.7K 5% 1/10W				
R1122	1-216-065-00	RES,CHIP	4.7K 5% 1/10W				
R1123	1-216-065-00	RES,CHIP	4.7K 5% 1/10W				
R1124	1-216-073-00	RES,CHIP	10K 5% 1/10W				
R1125	1-216-065-00	RES,CHIP	4.7K 5% 1/10W				
R1126	1-216-073-00	RES,CHIP	10K 5% 1/10W				
R1152	1-216-035-00	RES,CHIP	270 5% 1/10W (KV-21C5B/21X5B)				
R1153	1-216-025-00	RES,CHIP	100 5% 1/10W				
R1154	1-216-067-00	RES,CHIP	5.6K 5% 1/10W				
R1160	1-216-230-00	RES,CHIP	22K 5% 1/8W				
R1161	1-216-190-00	RES,CHIP	470 5% 1/8W				
R1162	1-216-061-00	RES,CHIP	3.3K 5% 1/10W				
R1163	1-216-081-00	RES,CHIP	22K 5% 1/10W				
R1164	1-216-073-00	RES,CHIP	10K 5% 1/10W (KV-21C5B/21X5B)				
R1165	1-216-295-00	SHORT	0 (KV-21C5D/21C5R) (KV-21X5A/21X5D/21X5R)				

The components identified by shading and marked Δ are critical for safety. Replace only with the part number specified.

REF. NO.	PART. NO.	DESCRIPTION	REMARK
< MISCELLANEOUS > *****			
Δ	1-411-922-11	COIL, DEGAUSSING	
	1-452-032-00	MAGNET, DISC; 10MM \emptyset	
	1-452-094-00	MAGNET, ROTATABLE DISC; 15MM \emptyset	
Δ	1-453-279-11	TRANSFORMER ASSY, FLYBACK NX-1747/U2B	
	1-505-924-11	SPEAKER (15X6.5CM)	
Δ	1-571-433-21	SWITCH, PUSH (AC POWER)	
Δ	1-756-286-11	CORD, POWER	
	1-693-418-11	TUNER (TELE9-001A) (KV-21C5B/21X5B)	
	8-598-432-00	TUNER (BTP-AC411) (KV-21C5D/21C5E/21C5K/21C5R 21X5A/21X5D/21X5E/215K/ 21X5R/21X5L)	
	8-598-464-01	TUNER (BTP-AU611) (KV-21X5U)	
Δ	8-738-784-05	PICTURE TUBE (SD-169) (A51JXH61X)	
Δ	8-451-295-45	DEFLECTION YOKE (Y21PFA2BA)	
Δ	8-738-787-71	ITC	
Δ	1-540-006-22	CAP ASSY, HIGH-VOLTAGE	

ACCESSORIES AND PACKING MATERIALS (KV-21C5)

*4-395-957-01	BAG PROTECTION	
*4-204-187-01	INDIVIDUAL CARTON	
*4-204-181-01	CUSHION (UPPER) (ASSY)	
*4-204-184-01	CUSHION (LOWER) (ASSY)	
4-204-358-51	MANUAL, INSTRUCTION (KV-21C5B) (FRENCH/GERMAN/ITALIAN/DUTCH)	
4-204-358-11	MANUAL, INSTRUCTION (KV-21CD) (GERMAN/ENGLISH/DUTCH/GREEK/TURKISH)	
4-204-358-71	MANUAL, INSTRUCTION (KV-21C5E) (SPANISH)	
4-204-358-81	MANUAL, INSTRUCTION (KV-21C5E) (PORTUGUESE/SWEDISH/DANISH/ NORWEGIAN/FINNISH)	
4-204-358-91	MANUAL, INSTRUCTION (KV-21C5K) (CZECH/ENGLISH/POLISH/HUNGARIAN)	
4-203-361-91	MANUAL, INSTRUCTION (KV-21C5R) (RUSSIAN/BULGARIAN/ENGLISH)	

REF. NO.	PART. NO.	DESCRIPTION	REMARK
ACCESSORIES AND PACKING MATERIALS (KV-21X5) *****			
	4-042-477-01	BAG PROTECTION	
	4-042-179-01	INDIVIDUAL CARTON	
	4-204-173-01	CUSHION (UPPER) (ASSY)	
	4-204-176-01	CUSHION (LOWER) (ASSY)	
	4-204-413-41	MANUAL INSTRUCTION (KV-21X5A) (ITALIAN)	
	4-204-413-51	MANUAL INSTRUCTION (KV-21X5B) (FRENCH/GERMAN/ITALIAN/DUTCH)	
	4-204-413-11	MANUAL INSTRUCTION (KV-21X5D) (GERMAN/ENGLISH/DUTCH/GREEK/TURKISH)	
	4-204-413-71	MANUAL INSTRUCTION (KV21X5E) (SPANISH)	
	4-204-413-91	MANUAL INSTRUCTION (KV-21X5K) (CZECH/ENGLISH/POLISH/HUNGARIAN)	
	4-204-414-61	MANUAL INSTRUCTION (KV-21X5L) (ENGLISH)	
	4-204-414-91	MANUAL INSTRUCTION (KV-21X5R) (RUSSIAN/BULGARIAN/ENGLISH)	
	4-204-413-61	MANUAL INSTRUCTION (KV-21X5U) (ENGLISH)	

REMOTE COMMANDER

1-475-765-11 COMMANDER STANDARD TYPE (RM883)
